

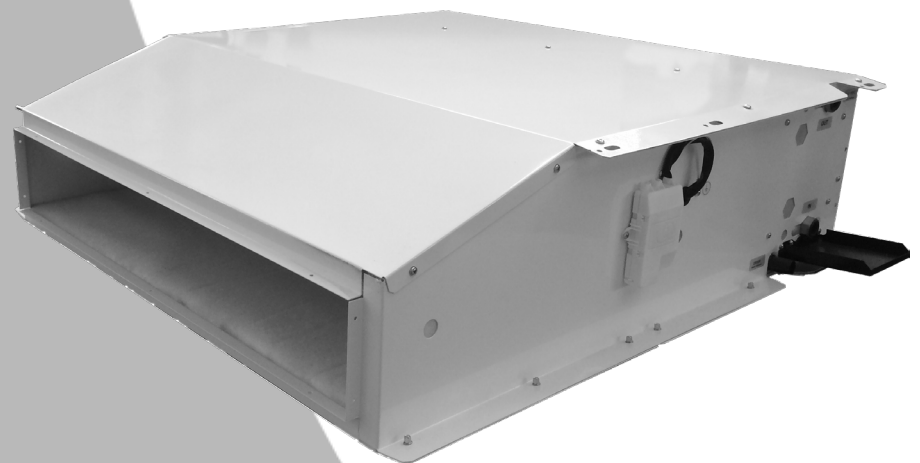

SERIES LNH



TECHNICAL MANUAL

Low Noise Hotel
FAN COILS



CONTENTS

1-INTRODUCTION	4
2-APPLICATION LIMITS.....	4
3-CODES INTERPRETATION KEY	4
4-CONTROL	5
5-TECHNICAL SPECIFICATIONS.....	6
6-TECHNICAL DATA (AC motors).....	7
6.1- 2-pipe unit	7
6.2- 4-pipe unit	9
7 - TECHNICAL DATA (EC motors).....	14
7.1- 2-pipe unit	14
7.2- 4-pipe unit	16
8-DIMENSIONS AND WEIGHTS	23
9-ACCESSORIES	25
9.1-Auxiliary coil (B1)	26
9.2-Valves (V)	26
9.3-Condensate drain pump (PSC).....	30
9.4-Flexible hoses with ball valves (DET).....	31
9.5-Transformer for modulating valves (TR24).....	31
9.6-Power relay board for master-slave (ETBN-2.5A)	32
9.7-Three-speed EC motor control board (SC3).....	32
9.8-Plenum with electrical heater (PEH) and relay (EHR)	33
9.9-Telescopic coupling (RT)	33
9.10-90° Delivery plenum (PM90).....	34
9.11-Delivery plenum with spigot (PMS).....	34
9.12-Air return flange (FRA).....	35
9.13-90° Intake plenum (PA90).....	35
9.14-Intake plenum with spigot (PAS).....	35
9.15-90° plenum with return grille and filter (PA90GF)	36
9.16-Dual adjustment delivery grille (GM2).....	37
9.17-Return grille (GR).....	37
9.18- Insulation for plenum (COIB)	38
9.19-Flange for external air intake (FLAE).....	38
9.20-Synthetic fibre filter (FAG3)	38
9.21-Filter in synthetic fibre with Sanitized treatment (FA/SAN).....	38
10-ELECTRICAL CONNECTIONS	39

1-INTRODUCTION

The units of the LNHseries are designed for air conditioning in the residential and retail sectors, for indoor installation not exposed to freezing or otherwise extreme temperatures, in non-dusty, non-explosive and non-aggressive environments (in particular with regard to the aluminium fins and the galvanized coating and/or paint finishing of the metal plates). The manufacturer may not be held liable for the consequences of incorrect use.

The units are designed to be ducted. Do not install them without ducting, as this might cause unit malfunction or damage. The manufacturer may not be held liable for the consequences of incorrect use.

The units are designed to minimise noise emissions, therefore, they are particularly suitable for installation in hotel rooms.

The basic unit consists of a filter, a heat exchange section (coil and condensation tray), a fan section (motor and fan) and an integrated silencer. A wide range of optional sections is also available as accessories (see the dedicated chapter), including optional filters, plenums and hydraulic accessories.

The LNH units are available with traditional three-speed motor (AC) and with low consumption motor (EC).

2-APPLICATION LIMITS

Electrical power supply	230V / 50 ÷ 60Hz (1)
Coil inlet water temperature	3 / 70°C
Maximum air delivery temperature (2)	50°C
Return air temperature	10 / 50°C

(1) +/-10% with respect to the nominal supply voltage. All technical data in this manual refer to 230V / 50Hz.

(2) In the case of water with a delivery flow temperature higher than 50°C, check the air delivery temperature using the TESI10 selection software.

The unit should only operate at the extremes of the above application limits briefly because operation at limit conditions for prolonged periods can reduce the normal lifetime of the unit's components.

3-CODES INTERPRETATION KEY

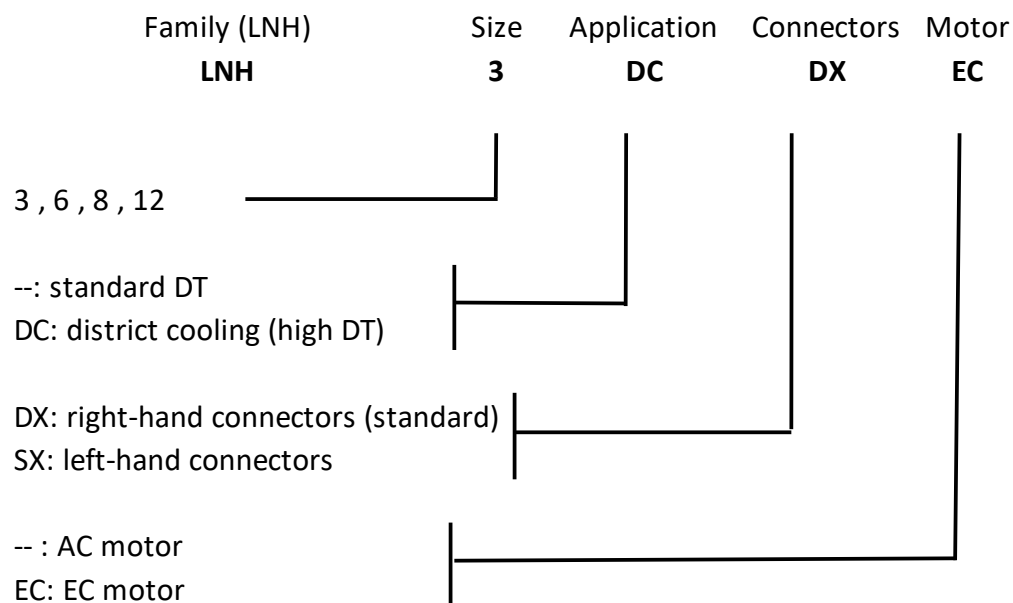

4-CONTROL

The units of the LNH series can be controlled by wall-mounted thermostats or by remote control. The remote control infrared receiver, with integrated temperature probe, is wall-mounted just like a common thermostat.

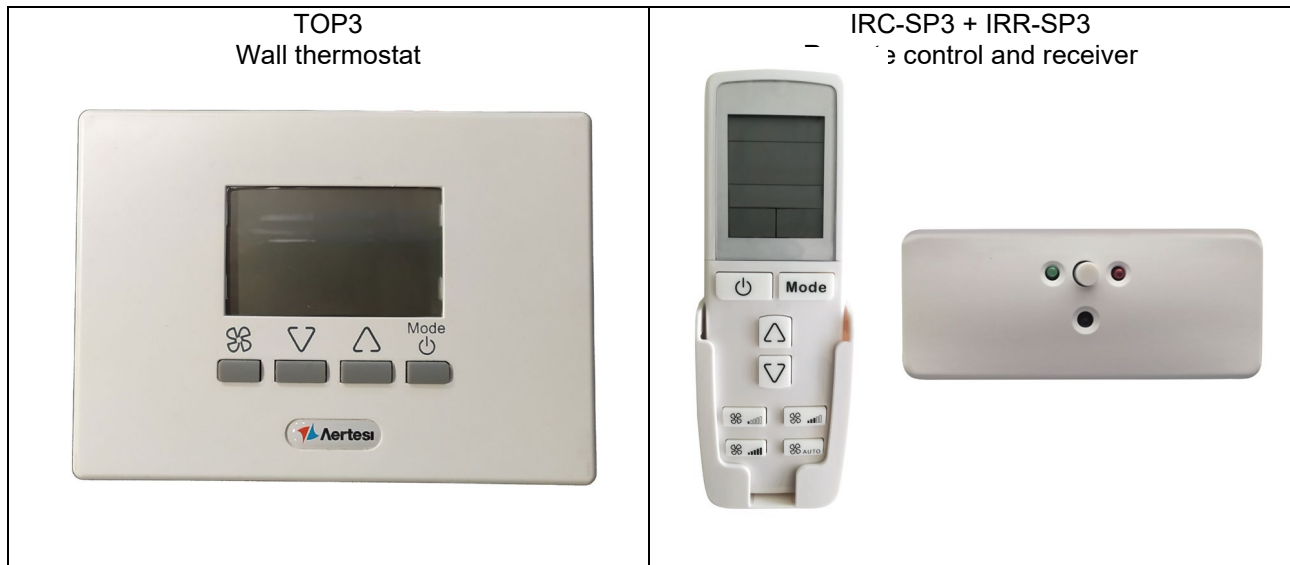

The use of thermostats with wall temperature probes, instead of machine on-board temperature probes, is recommended, because this ensures more accurate temperature detection thanks to better positioning of the temperature sensor.

The controls for units with AC motors must have contacts for the three motor speeds sized for at least 1A of inductive load, i.e. the highest power draw from the motor.

Direct connection (in parallel) of more than one unit with AC motor to the same control or to the same relay board is strictly not permitted. In this case, one relay board must be used for each unit (or a single relay board with dedicated contacts for each unit) such as the ETBN-2.5A board.

The controls for units with EC motor must have an output with 0/10V voltage signal sized to provide at least 0.2mA of current for each connected motor (the impedance of the driver's 0/10V input being 50kOhm). It is possible to connect several units with EC motor in parallel to the same control, until the maximum current rating of that control is reached, without interposing other boards.

Using the SC3 accessory, it is also possible to control the EC motor units using a traditional three-speed AC motor control.

For information on the proposed and approved controls for these units, please refer to the dedicated literature. Should you wish to use control types other than those proposed and approved by AERTESI, the manufacturers will not be held liable for any malfunctions caused by them.

5-TECHNICAL SPECIFICATIONS

FRAME: made of 0.80mm thick galvanized sheet steel. This rugged structure prevents the propagation of vibration and comes complete with ceiling fixing brackets.

ACCESSIBILITY: the filter can be removed from the bottom, without any tools being needed (if some accessories are installed at the intake end, please refer to the specific chapter of the manual for more information). Accessibility to internal components is obtained by removing the lower panel. The fan unit plate can be removed without having to disconnect the ducting. The hydraulic connectors are supplied as standard on the right side, and optionally on the left (viewed from in front of the fan-coil); the electrical panel is on the same side to improve accessibility.

FILTER: ISO COARSE class with ePM10 efficiency <50% (ISO 16890), 6mm thickness, in washable synthetic material. Other types on request.

FAN UNIT: the fans have forward curved blades and dual intake centrifuges directly coupled to the motor. The auger is made of galvanized steel or ABS, the fan is in aluminium or ABS (depending on the version and size of the motor). The motor and fans are balanced after installation on the fan unit plate. The motor is mounted on rubber vibration damping mounts, degree of protection IP20 and has three speeds (AC motor) or a 0-10V control (EC motor).

COIL: made from 3/8" diameter copper tubing (5/16" diameter for District Cooling special coils) with high efficiency corrugated aluminium fins and with manual air venting valve in the upper part of the manifold. Nominal pressure PN8. Direct expansion coils are available on request.

CONDENSATE COLLECTION TRAY: made of galvanized steel sheet and painted to prevent the formation of rust. The drain pipe and the edges are welded to avoid leaks over time. The tray is externally insulated with thermal insulation and is installed to an angle in the direction of the drain pipe to avoid standing water.

INSULATION: the heat exchange unit and the tray are insulated with 3mm thick polyethylene, to prevent condensation on the structural metalwork. The fan and silencer section is insulated with 25mm thick textured polyurethane, fire reaction class HF1 according to the UL94 standard.

ELECTRICAL CONTROL PANEL: made of galvanized sheet steel or plastic and positioned on the same side with respect to the hydraulic connectors to improve accessibility. If the machine is equipped with a factory-installed control board (e.g. SP3), all the electrical parts of the fan coil (motor, valves, etc.) are pre-connected to the manufacturer's control. While if the machine is supplied ready to be connected to a wall-mounted control, the electrical devices are connected to a terminal block, to which the installer will, in turn, connect.

6-TECHNICAL DATA (AC motors)

This chapter lists the operating specifications of the units with 4-row main coils and 1-row auxiliary coils.
The District Cooling coils are also available from our selection software.

6.1- 2-pipe unit

		3						6					
		4 rows						4 rows					
Speed		1	2	3	4	5	6	1	2	3	4	5	6
			MIN		MED	MAX			MIN		MED	MAX	
Air flow rate	mc/h	178	191	265	313	361	433	286	308	420	495	577	692
COOLING - air 27 °C (dry bulb), 19 °C w.b. - water inlet 7 °C, outlet 12 °C													
Total capacity	kW	1,36	1,44	1,87	2,14	2,39	2,73	1,98	2,11	2,71	3,08	3,47	3,98
Sensitive capacity	kW	0,95	1,01	1,33	1,54	1,73	2,00	1,39	1,48	1,94	2,22	2,53	2,94
Water flow rate	l/h	235	249	326	372	415	476	344	366	471	537	604	692
Δp (water)	kPa	7,8	8,7	14,3	18,3	22,5	29,0	3,5	4,0	6,3	8,1	10,0	12,9
HEATING - air 20 °C - water inlet 45 °C, outlet 40 °C													
Capacity	kW	1,29	1,39	1,86	2,16	2,44	2,85	1,92	2,04	2,72	3,15	3,59	4,20
Water flow rate	l/h	222	237	318	369	416	486	328	350	465	537	614	717
Δp (water)	kPa	6,3	7,1	12,3	16,2	20,4	27,2	2,9	3,3	5,6	7,3	9,4	12,5
MOTOR ELECTRIC POWER DRAW													
Power draw	W	13	15	22	28	32	41	18	21	30	36	43	54
Max power draw	A	0,19						0,24					
SOUND DATA													
Inlet +radiated sound power dB(A)	dB(A)	29	32	35	39	42	44	27	29	33	36	40	42
Inlet + radiated sound pressure dB(A) (*)	dB(A)	17	20	23	27	30	32	15	17	21	24	28	30
Outlet sound power dB(A)	dB(A)	26	29	32	36	39	41	24	26	30	33	37	39
Outlet sound pressure dB(A) (*)	dB(A)	14	17	20	24	27	29	12	14	18	21	25	27

(*) Values given as a guideline for units with non-ducted intake and with ducted discharge, and for room and installation attenuation of 12 dB (size 3 to 8) and 14 dB (size 12).

Speed		8						12					
		4 rows						4 rows					
		1	2	3	4	5	6	1	2	3	4	5	6
			MIN		MED	MAX			MIN		MED	MAX	
Air flow rate	mc/h	408	439	600	708	835	1044	668	719	966	1131	1263	1579
COOLING - air 27 °C (dry bulb), 19 °C w.b. - water inlet 7 °C, outlet 12 °C													
Total capacity	kW	3,12	3,32	4,27	4,86	5,50	6,50	4,66	4,92	6,14	6,88	7,44	8,55
Sensitive capacity	kW	2,17	2,31	3,02	3,48	3,98	4,77	3,32	3,52	4,49	5,09	5,54	6,55
Water flow rate	l/h	544	577	744	848	962	1136	812	858	1072	1204	1302	1499
Δp (water)	kPa	9,7	10,9	17,4	22,2	28,1	38,3	20,5	22,7	34,4	42,6	49,4	64,2
HEATING - air 20 °C - water inlet 45 °C, outlet 40 °C													
Capacity	kW	2,98	3,19	4,23	4,89	5,64	6,82	4,64	4,95	6,39	7,29	7,98	9,53
Water flow rate	l/h	509	544	721	833	961	1160	793	844	1088	1240	1356	1619
Δp (water)	kPa	7,7	8,7	14,7	19,3	25,2	35,8	17,6	19,8	31,8	40,6	48,0	67,0
MOTOR ELECTRIC POWER DRAW													
Power draw	W	36	44	60	73	89	108	56	68	96	116	137	167
Max power draw	A	0,47						0,74					
SOUND DATA													
Inlet +radiated sound power dB(A)	dB(A)	27	32	38	41	45	46	35	40	47	51	54	55
Inlet + radiated sound pressure dB(A) (*)	dB(A)	15	20	26	29	33	34	21	26	33	37	40	41
Outlet sound power dB(A)	dB(A)	25	29	35	38	42	43	32	37	44	48	51	52
Outlet sound pressure dB(A) (*)	dB(A)	13	17	23	26	30	31	18	23	30	34	37	38

(*) Values given as a guideline for units with non-ducted intake and with ducted discharge, and for room and installation attenuation of 12 dB (size 3 to 8) and 14 dB (size 12).

6.2- 4-pipe unit

Speed		3+B1						6+B1					
		4 rows+1						4 rows+1					
		1	2	3	4	5	6	1	2	3	4	5	6
			MIN		MED	MAX			MIN		MED	MAX	
Air flow rate	mc/h	178	191	265	313	361	433	286	308	420	495	577	692
COOLING - air 27 °C (dry bulb), 19 °C w.b. - water inlet 7 °C, outlet 12 °C													
Total capacity	kW	1,36	1,44	1,87	2,14	2,39	2,73	1,98	2,11	2,71	3,08	3,47	3,98
Sensitive capacity	kW	0,95	1,01	1,33	1,54	1,73	2,00	1,39	1,48	1,94	2,22	2,53	2,94
Water flow rate	l/h	235	249	326	372	415	476	344	366	471	537	604	692
Δp (water)	kPa	7,8	8,7	14,3	18,3	22,5	29,0	3,5	4,0	6,3	8,1	10,0	12,9
HEATING - air 20 °C - water inlet 65 °C, outlet 55 °C													
Capacity	kW	1,19	1,26	1,59	1,80	1,99	2,22	1,85	1,95	2,45	2,77	3,09	3,51
Water flow rate	l/h	103	108	137	155	171	190	159	168	211	238	266	302
Δp (water)	kPa	2,9	3,2	5,0	6,3	7,7	9,3	8,2	9,1	13,9	17,4	21,4	27,2
MOTOR ELECTRIC POWER DRAW													
Power draw	W	13	15	22	28	32	41	18	21	30	36	43	54
Max power draw	A	0,19						0,24					
SOUND DATA													
Inlet +radiated sound power dB(A)	dB(A)	29	32	35	39	42	44	27	29	33	36	40	42
Inlet + radiated sound pressure dB(A) (*)	dB(A)	17	20	23	27	30	32	15	17	21	24	28	30
Outlet sound power dB(A)	dB(A)	26	29	32	36	39	41	24	26	30	33	37	39
Outlet sound pressure dB(A) (*)	dB(A)	14	17	20	24	27	29	12	14	18	21	25	27

Values given as a guideline for units with non-ducted intake and with ducted discharge, and for room and installation attenuation of 12 dB (size 3 to 8) and 14 dB (size 12).

		8+B1						12+B1					
		4 rows+1						4 rows+1					
Speed		1	2	3	4	5	6	1	2	3	4	5	6
			MIN		MED	MAX			MIN		MED	MAX	
Air flow rate	mc/h	408	439	600	708	835	1044	668	719	966	1131	1263	1579
COOLING - air 27 °C (dry bulb), 19 °C w.b. - water inlet 7 °C, outlet 12 °C													
Total capacity	kW	3,12	3,32	4,27	4,86	5,50	6,50	4,66	4,92	6,14	6,88	7,44	8,55
Sensitive capacity	kW	2,17	2,31	3,02	3,48	3,98	4,77	3,32	3,52	4,49	5,09	5,54	6,55
Water flow rate	l/h	544	577	744	848	962	1136	812	858	1072	1204	1302	1499
Δp (water)	kPa	9,7	10,9	17,4	22,2	28,1	38,3	20,5	22,7	34,4	42,6	49,4	64,2
HEATING - air 20 °C - water inlet 65 °C, outlet 55 °C													
Capacity	kW	2,74	2,89	3,63	4,09	4,60	5,26	3,92	4,13	5,00	5,55	5,97	6,89
Water flow rate	l/h	235	248	311	350	393	449	336	354	427	473	508	586
Δp (water)	kPa	5,1	5,7	8,7	10,9	13,6	17,6	10,1	11,2	16,0	19,5	22,3	29,5
MOTOR ELECTRIC POWER DRAW													
Power draw	W	36	44	60	73	89	108	56	68	96	116	137	167
Max power draw	A	0,47						0,74					
SOUND DATA													
Inlet + radiated sound power dB(A)	dB(A)	27	32	38	41	45	46	35	40	47	51	54	55
Inlet + radiated sound pressure dB(A) (*)	dB(A)	15	20	26	29	33	34	21	26	33	37	40	41
Outlet sound power dB(A)	dB(A)	25	29	35	38	42	43	32	37	44	48	51	52
Outlet sound pressure dB(A) (*)	dB(A)	13	17	23	26	30	31	18	23	30	34	37	38

Values given as a guideline for units with non-ducted intake and with ducted discharge, and for room and installation attenuation of 12 dB (size 3 to 8) and 14 dB (size 12).

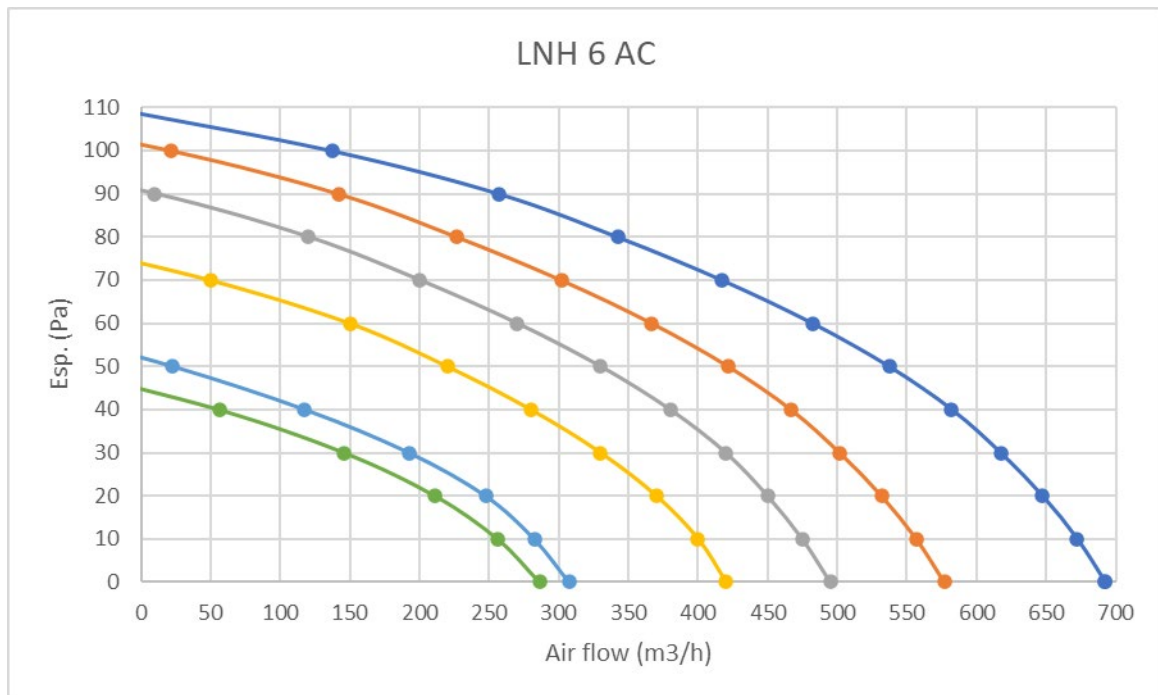
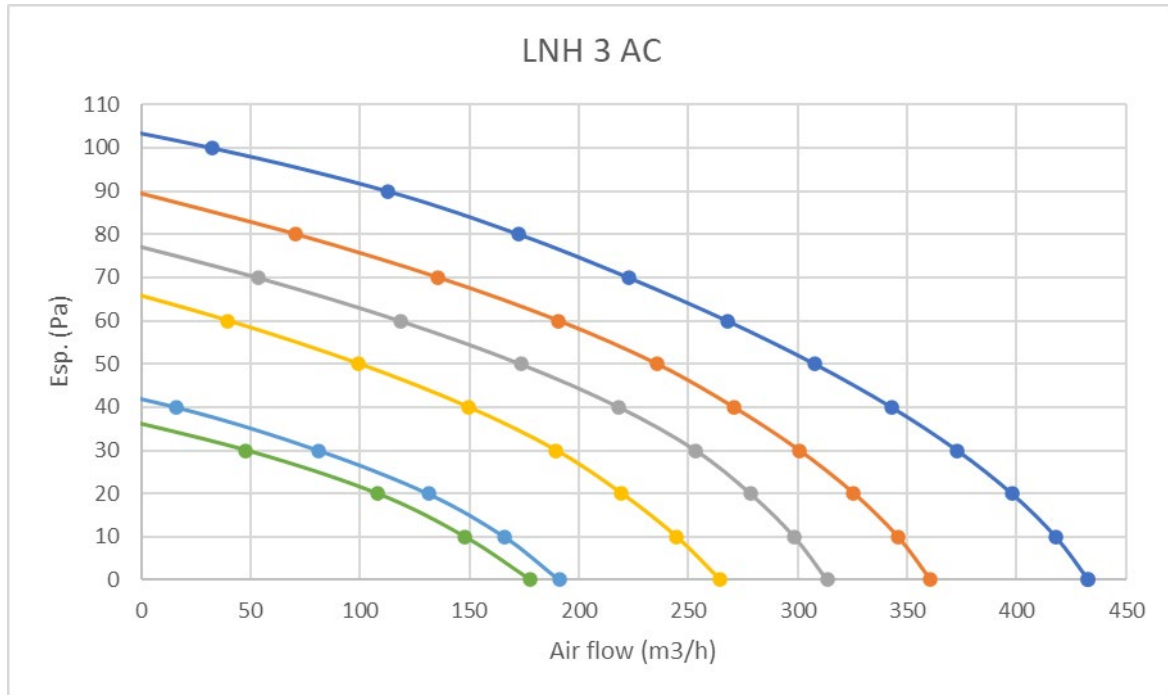

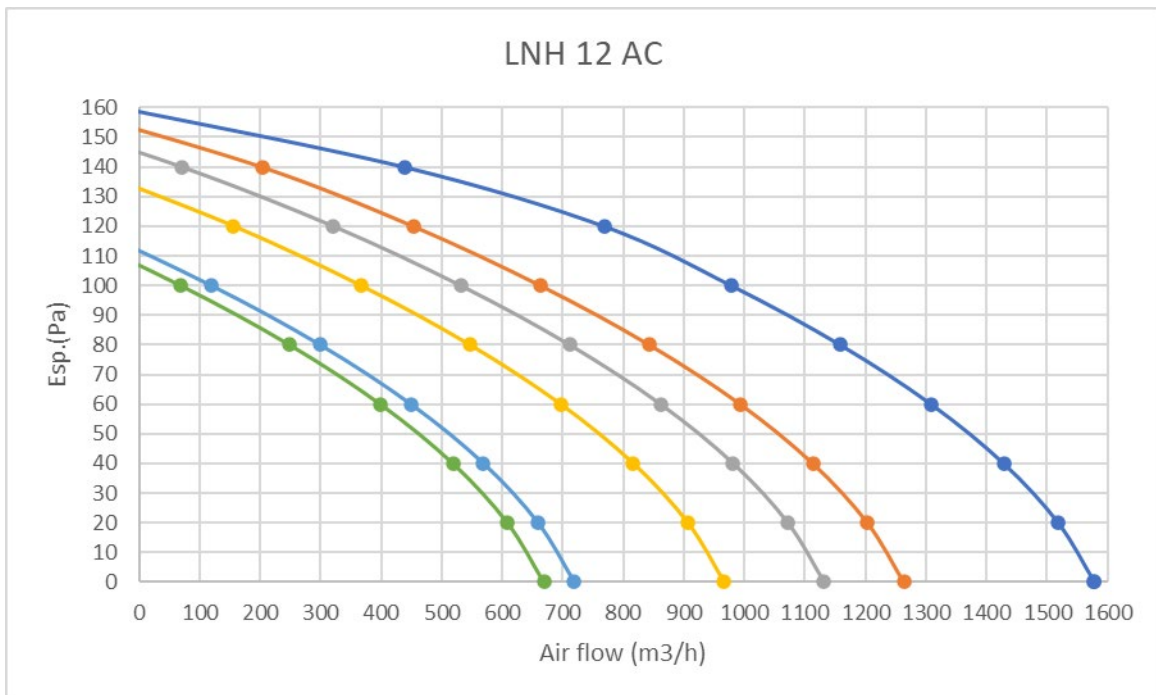
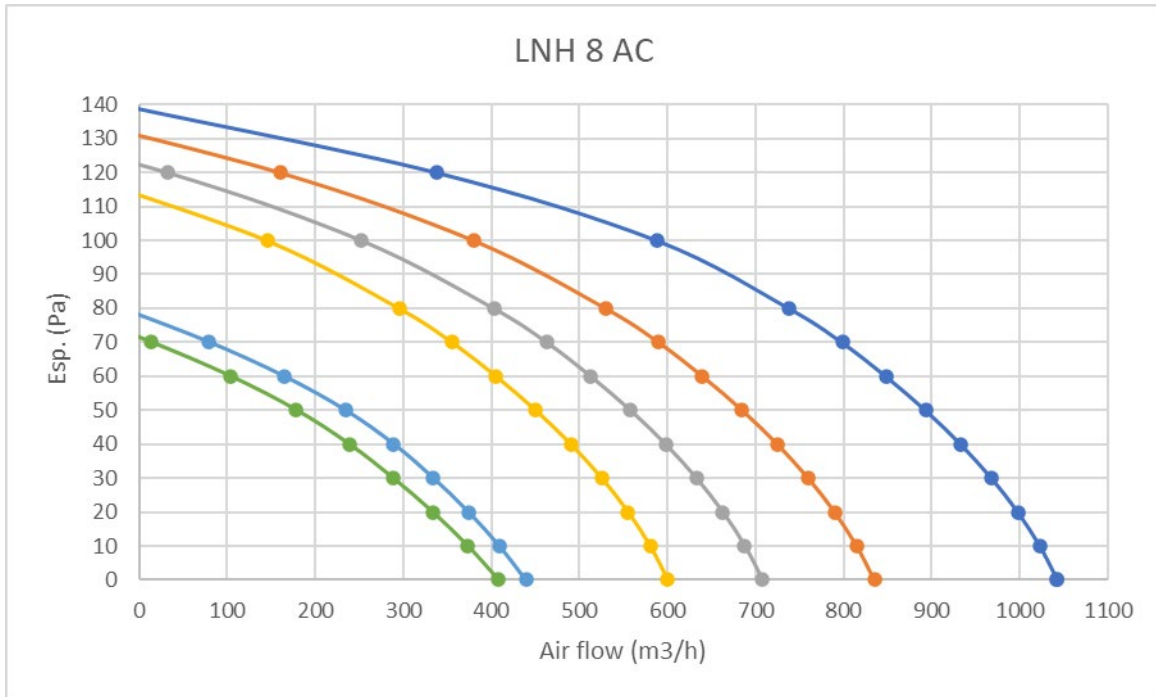

Sound power level INLET + RADIATED [dB] e Sound power level OUTLET [dB].

	Velocità	Sound power									Sound pressure dB(A)	NR	
		125Hz	250Hz	500Hz	1000Hz	2000Hz	4000Hz	8000Hz	TOTAL				
		dB	dB	dB	dB	dB	dB	dB	dB	dB(A)			
LNH 3	Inlet+ radiated	1	36,8	27,5	23,5	17,8	18,7	20,1	21,3	37,7	29	<20	/
		2-min	39,6	31,8	28,4	20,7	20,8	22,0	23,1	40,8	32	<20	/
		3	42,5	36,3	34,4	27,1	22,5	22,2	22,8	44,1	35	23	/
		4-med	44,1	40,0	38,7	31,8	28,3	23,1	23,6	46,6	39	27	/
		5-max	44,4	42,6	41,4	35,2	33,0	24,1	23,3	48,2	42	30	/
		6	44,9	44,2	43,0	37,7	35,9	26,5	21,5	49,4	44	32	/
	Outlet	1	33,8	24,5	20,5	14,8	15,7	17,1	18,3	34,7	<28	<20	14
		2-min	36,6	28,8	25,4	17,7	17,8	19,0	20,1	37,8	29	<20	16
		3	39,5	33,3	31,4	24,1	19,5	19,2	19,8	41,1	32	20	15
		4-med	41,1	37,0	35,7	28,8	25,3	20,1	20,6	43,6	36	24	20
		5-max	41,4	39,6	38,4	32,2	30,0	21,1	20,3	45,2	39	27	22
		6	41,9	41,2	40,0	34,7	32,9	23,5	18,5	46,4	41	29	24
LNH 6	Inlet+ radiated	1	32,0	25,2	21,7	17,1	18,6	19,9	21,0	33,8	<28	<20	/
		2-min	33,5	29,0	25,7	18,6	19,8	21,1	22,1	35,9	29	<20	/
		3	34,2	34,8	32,7	24,1	20,6	21,1	22,1	39,1	33	21	/
		4-med	35,5	37,7	36,0	28,4	23,9	21,2	21,8	41,7	36	24	/
		5-max	36,9	41,2	40,0	32,9	29,8	21,8	22,3	45,0	40	28	/
		6	38,0	42,6	41,8	35,2	33,4	22,6	20,1	46,6	42	30	/
	Outlet	1	29,0	22,2	18,7	14,1	15,6	16,9	18,0	30,8	<28	<20	14
		2-min	30,5	26,0	22,7	15,6	16,8	18,1	19,1	32,9	<28	<20	16
		3	31,2	31,8	29,7	21,1	17,6	18,1	19,1	36,1	30	<20	15
		4-med	32,5	34,7	33,0	25,4	20,9	18,2	18,8	38,7	33	21	17
		5-max	33,9	38,2	37,0	29,9	26,8	18,8	19,3	42,0	37	25	21
		6	35,0	39,6	38,8	32,2	30,4	19,6	17,1	43,6	39	27	23
LNH 8	Inlet+ radiated	1	32,9	27,6	22,9	16,6	17,6	19,2	20,2	34,8	<28	<20	/
		2-min	36,9	33,8	29,5	22,7	21,3	22,9	23,7	39,5	32	20	/
		3	38,3	39,7	37,3	30,9	28,7	22,8	23,2	43,8	38	26	/
		4-med	39,9	42,0	40,4	33,4	33,6	22,3	22,5	46,2	41	29	/
		5-max	42,4	45,5	44,6	37,6	37,8	25,3	23,2	49,7	45	33	/
		6	41,7	45,9	45,2	39,1	38,7	29,1	20,3	50,1	46	34	/
	Outlet	1	29,9	24,6	19,9	13,6	14,6	16,2	17,2	31,8	<28	<20	13
		2-min	33,9	30,8	26,5	19,7	18,3	19,9	20,7	36,5	29	<20	16
		3	35,3	36,7	34,3	27,9	25,7	19,8	20,2	40,8	35	23	18
		4-med	36,9	39,0	37,4	30,4	30,6	19,3	19,5	43,2	38	26	22
		5-max	39,4	42,5	41,6	34,6	34,8	22,3	20,2	46,7	42	30	26
		6	38,7	42,9	42,2	36,1	35,7	26,1	17,3	47,1	43	31	27
LNH 12	Inlet+ radiated	1	33,2	36,7	35,2	27,5	24,3	17,7	18,4	40,4	35	21	/
		2-min	37,0	41,0	40,3	32,6	30,8	20,6	20,4	45,0	40	26	/
		3	42,4	47,1	46,5	40,2	39,2	30,3	20,9	51,2	47	33	/
		4-med	45,8	50,9	50,1	44,4	43,3	36,7	24,8	55,0	51	37	/
		5-max	48,3	53,7	52,7	47,6	46,1	41,3	29,2	57,8	54	40	/
		6	49,6	54,6	53,6	48,7	46,9	43,2	31,6	58,8	55	41	/
	Outlet	1	30,2	33,7	32,2	24,5	21,3	14,7	15,4	37,4	32	<20	14
		2-min	34,0	38,0	37,3	29,6	27,8	17,6	17,4	42,0	37	23	19
		3	39,4	44,1	43,5	37,2	36,2	27,3	17,9	48,2	44	30	26
		4-med	42,8	47,9	47,1	41,4	40,3	33,7	21,8	52,0	48	34	29
		5-max	45,3	50,7	49,7	44,6	43,1	38,3	26,2	54,8	51	37	32
		6	46,6	51,6	50,6	45,7	43,9	40,2	28,6	55,8	52	38	33

7 - TECHNICAL DATA (EC motors)

This chapter lists the operating specifications of the units with 4-row main coils and 1-row auxiliary coils.
The District Cooling coils are also available from our selection software.

7.1- 2-pipe unit

Speed (Drive voltage)		3					6				
		4 rows					4 rows				
		1V	3V	4V	7V	10V	1V	4V	5V	7V	10V
			MIN	MED	MAX		Min	MED	MAX		
Air flow rate	mc/h	90	190	236	368	539	194	424	499	652	937
COOLING - air 27 °C (dry bulb), 19 °C w.b. - water inlet 7 °C, outlet 12 °C											
Total capacity	kW	0,75	1,44	1,72	2,44	3,21	1,44	2,75	3,13	3,84	4,96
Sensitive capacity	kW	0,51	1,01	1,22	1,77	2,41	0,99	1,97	2,27	2,83	3,79
Water flow rate	l/h	130	249	297	421	555	247	475	540	663	858
Δp (water)	kPa	2,6	8,7	12,1	23,1	38,6	1,9	6,4	8,1	11,9	19,4
HEATING - air 20 °C - water inlet 45 °C, outlet 40 °C											
Capacity	kW	0,68	1,37	1,67	2,46	3,39	1,33	2,72	3,14	3,96	5,35
Water flow rate	l/h	116	236	287	423	582	228	468	541	682	921
Δp (water)	kPa	1,9	7,0	10,2	21,0	38,2	1,5	5,6	7,4	11,4	20,1
MOTOR ELECTRIC POWER DRAW											
Power draw	W	4	7	8	13	22	5	10	13	19	34
Max power draw	A	0,19					0,27				
SOUND DATA											
Inlet + radiated sound power dB(A)	dB(A)	25	31	34	42	45	24	33	36	42	45
Inlet + radiated sound pressure dB(A) (*)	dB(A)	13	19	22	30	33	12	21	24	30	33
Outlet sound power dB(A)	dB(A)	23	28	31	39	42	22	30	33	39	42
Outlet sound pressure dB(A) (*)	dB(A)	11	16	19	27	30	10	18	21	27	30

(*) Values given as a guideline for units with non-ducted intake and with ducted discharge, and for room and installation attenuation of 12 dB (size 3 to 8) and 14 dB (size 12).

Speed (Drive voltage)		8					12				
		4 rows					4 rows				
		1V	5V	7V	9V	10V	1V	4V	5V	8V	10V
			MIN	MED	MAX		MIN	MED	MAX		
Air flow rate	mc/h	226	525	681	824	939	217	646	811	1231	1561

COOLING - air 27 °C (dry bulb), 19 °C w.b. - water inlet 7 °C, outlet 12 °C

Total capacity	kW	1,89	3,88	4,76	5,51	6,08	1,82	4,57	5,45	7,35	8,56
Sensitive capacity	kW	1,28	2,74	3,41	4,00	4,45	1,24	3,26	3,95	5,49	6,57
Water flow rate	l/h	326	669	822	952	1050	313	789	943	1276	1488
Δp (water)	kPa	3,8	14,3	21,0	27,5	33,1	3,5	19,4	27,1	47,5	63,4

HEATING - air 20 °C - water inlet 45 °C, outlet 40 °C

Capacity	kW	1,70	3,71	4,68	5,52	6,17	1,63	4,47	5,45	7,74	9,36
Water flow rate	l/h	293	640	806	950	1062	281	769	937	1328	1604
Δp (water)	kPa	2,7	11,8	18,1	24,7	30,3	2,6	16,6	24,0	46,1	65,8

MOTOR ELECTRIC POWER DRAW

Power draw	W	6	13	19	27	31	5	18	28	74	89
Max power draw	A	0,26					0,67				

SOUND DATA

Inlet + radiated sound power dB(A)	dB(A)	23	35	41	45	46	24	39	44	53	55
Inlet + radiated sound pressure dB(A) (*)	dB(A)	11	23	29	33	34	10	25	30	39	41
Outlet sound power dB(A)	dB(A)	21	32	38	42	43	21	36	41	50	52
Outlet sound pressure dB(A) (*)	dB(A)	9	20	26	30	31	7	22	27	36	38

(*) Values given as a guideline for units with non-ducted intake and with ducted discharge, and for room and installation attenuation of 12 dB (size 3 to 8) and 14 dB (size 12).

7.2- 4-pipe unit

		3+B1					6+B1				
		4 rows + 1					4 rows + 1				
Speed (Drive voltage)		1V	3V	4V	7V	10V	1V	4V	5V	7V	10V
			MIN	MED	MAX			Min	MED	MAX	
Air flow rate	mc/h	90	190	236	368	539	194	424	499	652	937
COOLING - air 27 °C (dry bulb), 19 °C w.b. - water inlet 7 °C, outlet 12 °C											
Total capacity	kW	0,75	1,44	1,72	2,44	3,21	1,44	2,75	3,13	3,84	4,96
Sensitive capacity	kW	0,51	1,01	1,22	1,77	2,41	0,99	1,97	2,27	2,83	3,79
Water flow rate	l/h	130	249	297	421	555	247	475	540	663	858
Δp (water)	kPa	2,6	8,65	12,05	23,05	38,6	1,9	6,4	8,1	11,9	19,4
HEATING - air 20 °C - water inlet 65 °C, outlet 55 °C											
Capacity	kW	0,71	1,25	1,46	2,00	2,53	1,37	2,45	2,75	3,34	4,19
Water flow rate	l/h	61	108	126	173	219	119	213	239	290	363
Δp (water)	kPa	1,1	3,2	4,3	7,8	12,2	4,8	14,1	17,6	25,2	38,4
MOTOR ELECTRIC POWER DRAW											
Power draw	W	4	7	8	13	22	5	10	13	19	34
Max power draw	A	0,19					0,27				
SOUND DATA											
Inlet +radiated sound power dB(A)	dB(A)	25	31	34	42	45	24	33	36	42	45
Inlet + radiated sound pressure dB(A) (*)	dB(A)	13	19	22	30	33	12	21	24	30	33
Outlet sound power dB(A)	dB(A)	23	28	31	39	42	22	30	33	39	42
Outlet sound pressure dB(A) (*)	dB(A)	11	16	19	27	30	10	18	21	27	30

(*) Values given as a guideline for units with non-ducted intake and with ducted discharge, and for room and installation attenuation of 12 dB (size 3 to 8) and 14 dB (size 12).

		8+B1					12+B1				
		4 rows + 1					4 rows + 1				
Speed (Drive voltage)		1V	5V	7V	9V	10V	1V	4V	5V	8V	10V
			MIN	MED	MAX			MIN	MED	MAX	
Air flow rate	mc/h	226	525	681	824	939	217	646	811	1231	1561
COOLING - air 27 °C (dry bulb), 19 °C w.b. - water inlet 7 °C, outlet 12 °C											
Total capacity	kW	1,89	3,88	4,76	5,51	6,08	1,82	4,57	5,45	7,35	8,56
Sensitive capacity	kW	1,28	2,74	3,41	4,00	4,45	1,24	3,26	3,95	5,49	6,57
Water flow rate	l/h	326	669	822	952	1050	313	789	943	1276	1488
Δp (water)	kPa	3,8	14,3	21,0	27,5	33,1	3,5	19,4	27,1	47,5	63,4
HEATING - air 20 °C - water inlet 65 °C, outlet 55 °C											
Capacity	kW	1,75	3,25	3,93	4,50	4,91	1,69	3,79	4,45	5,80	6,76
Water flow rate	l/h	151	283	341	390	425	146	328	386	500	581
Δp (water)	kPa	2,15	7,3	10,4	13,4	15,9	2,0	9,6	13,2	21,7	29,0
MOTOR ELECTRIC POWER DRAW											
Power draw	W	6	13	19	27	31	5	18	28	74	89
Max power draw	A	0,26					0,67				
SOUND DATA											
Inlet + radiated sound power dB(A)	dB(A)	23	35	41	45	46	24	39	44	53	55
Inlet + radiated sound pressure dB(A) (*)	dB(A)	11	23	29	33	34	10	25	30	39	41
Outlet sound power dB(A)	dB(A)	21	32	38	42	43	21	36	41	50	52
Outlet sound pressure dB(A) (*)	dB(A)	9	20	26	30	31	7	22	27	36	38

(*) Values given as a guideline for units with non-ducted intake and with ducted discharge, and for room and installation attenuation of 12 dB (size 3 to 8) and 14 dB (size 12).

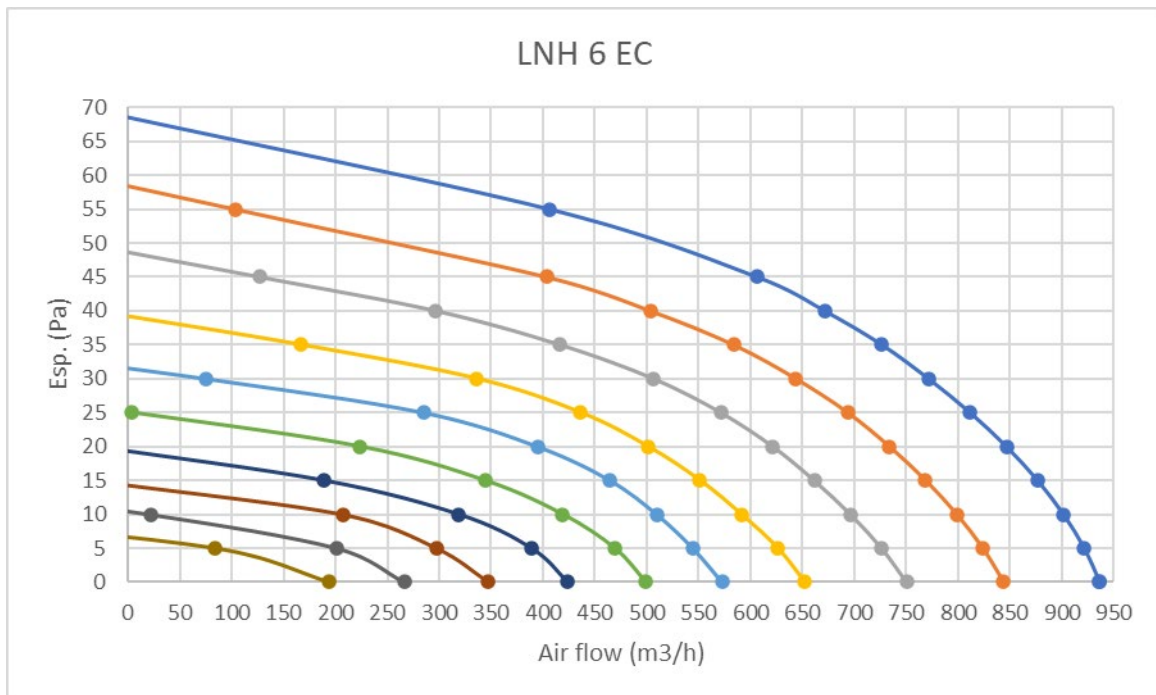
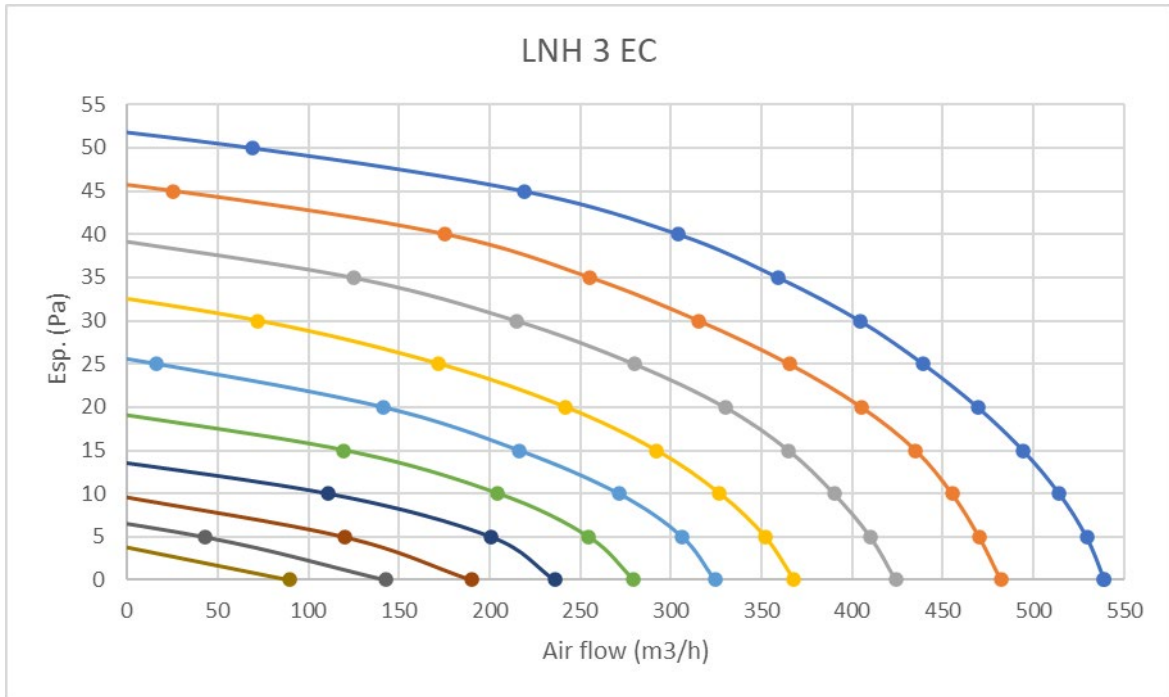

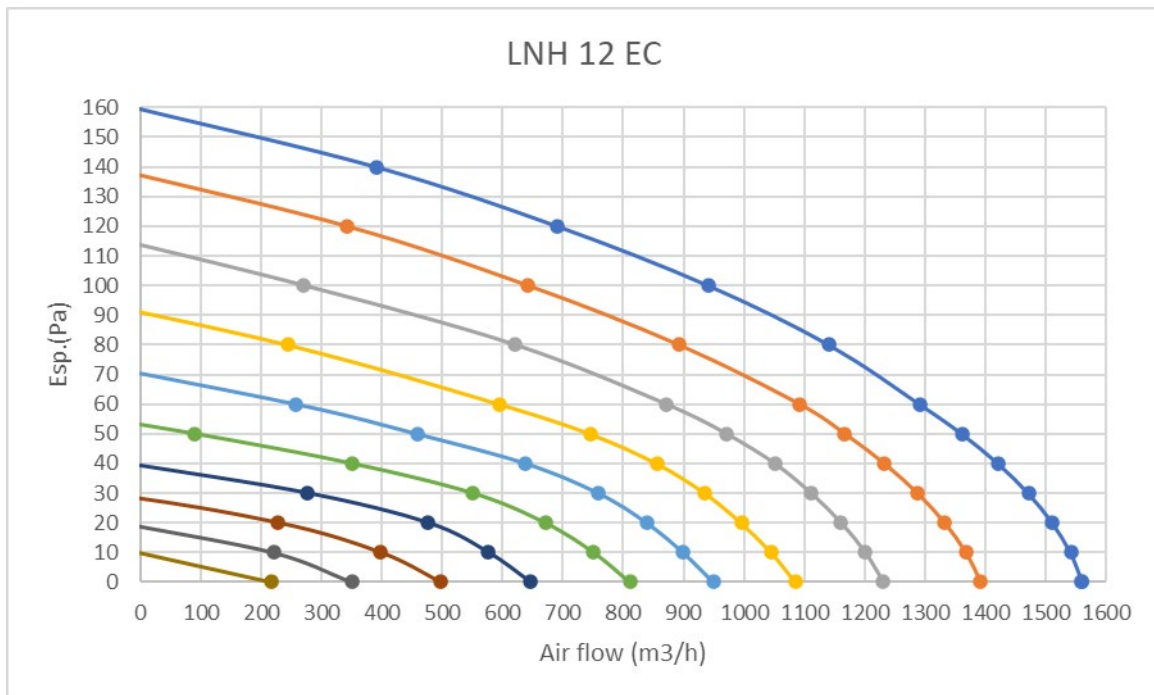
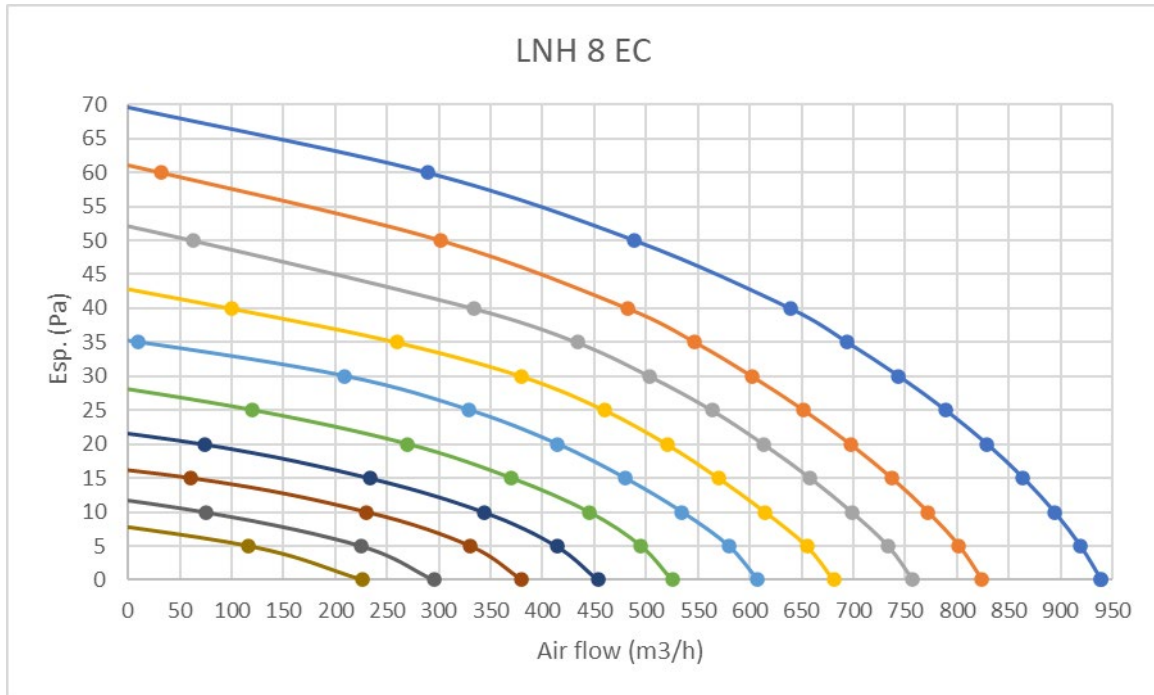

Sound power level INLET + RADIATED [dB] and Sound power level OUTLET [dB].

	Speed	Sound power									Sound pressure	NR	
		125Hz	250Hz	500Hz	1000Hz	2000Hz	4000Hz	8000Hz	TOTALE				
		dB	dB	dB	dB	dB	dB	dB	dB	dB(A)	dB(A)		
LNH 3	Inlet + radiated	1V	34,7	19,3	15,9	14,7	16,9	18,1	19,1	35,2	<28	<20	/
		2V	34,7	24,4	19,8	17,1	18,7	20	20,9	35,6	<28	<20	/
		3V	37	32,3	28,6	20,6	20,6	22,2	22,9	39,0	31	<20	/
		4V	39,5	35,8	33,6	24,1	21,5	22,5	23,2	42,0	34	22	/
		5V	35,7	37,6	36,6	27,5	23,2	21,8	22,4	41,8	36	24	/
		6V	37,2	40,4	39,4	31,3	27,4	21,9	22,4	44,3	39	27	/
		7V	38,3	43,2	42,3	34,8	31,7	23,5	23,1	47,0	42	30	/
		8V	39,4	43,9	43	36,1	33,4	24,6	22,1	47,8	43	31	/
		9V	38,6	44,5	43,7	37,3	34,9	26,2	20,9	48,3	44	32	/
		10V	39,2	45,3	44,5	38,6	36,3	28,2	20,5	49,2	45	33	/
	Outlet	1V	31,7	16,3	12,9	11,7	13,9	15,1	16,1	32,2	<28	<20	12
		2V	31,7	21,4	16,8	14,1	15,7	17	17,9	32,6	<28	<20	14
		3V	34	29,3	25,6	17,6	17,6	19,2	19,9	36,0	28	<20	15
		4V	36,5	32,8	30,6	21,1	18,5	19,5	20,2	39,0	31	<20	16
		5V	32,7	34,6	33,6	24,5	20,2	18,8	19,4	38,8	33	21	17
		6V	34,2	37,4	36,4	28,3	24,4	18,9	19,4	41,3	36	24	20
		7V	35,3	40,2	39,3	31,8	28,7	20,5	20,1	44,0	39	27	23
		8V	36,4	40,9	40	33,1	30,4	21,6	19,1	44,8	40	28	24
		9V	35,6	41,5	40,7	34,3	31,9	23,2	17,9	45,3	41	29	25
		10V	36,2	42,3	41,5	35,6	33,3	25,2	17,5	46,2	42	30	26

	Speed	Sound power									Sound pressure	NR	
		125Hz	250Hz	500Hz	1000Hz	2000Hz	4000Hz	8000Hz	500Hz	1000Hz			
		dB	dBA	dB	dB	dB	dB	dB	dB	dB	dB		dB(A)
LNH 6	Inlet + radiated	1V	29	18	15,1	13,5	17,7	17,4	18,1	30,4	<28	<20	/
		2V	30,4	24,1	20,5	15,4	18,8	18,9	19,6	32,4	<28	<20	/
		3V	33,2	32,2	27,7	18,9	20,7	21	21,6	36,8	30	<20	/
		4V	34,5	34,9	32,5	23,7	22	21,6	22,1	39,2	33	21	/
		5V	34,7	37,8	36,2	28	24	20,8	21,9	41,6	36	24	/
		6V	36,2	41,7	38,9	31,5	27,4	21,3	21,8	44,6	39	27	/
		7V	37,9	43	42,1	35,2	31,9	22,9	22,3	46,8	42	30	/
		8V	38,9	43,7	42,9	36,4	33,5	23,8	21,1	47,6	43	31	/
		9V	38,7	44,5	43,7	37,6	35	25,6	20	48,4	44	32	/
	10V	39,4	45,3	44,6	38,7	36,3	27,5	19,5	49,2	45	33	/	
	Outlet	1V	26	15	12,1	10,5	14,7	14,4	15,1	27,4	<28	<20	11
		2V	27,4	21,1	17,5	12,4	15,8	15,9	16,6	29,4	<28	<20	12
		3V	30,2	29,2	24,7	15,9	17,7	18	18,6	33,8	<28	<20	14
		4V	31,5	31,9	29,5	20,7	19	18,6	19,1	36,2	30	<20	15
		5V	31,7	34,8	33,2	25	21	17,8	18,9	38,6	33	21	17
		6V	33,2	38,7	35,9	28,5	24,4	18,3	18,8	41,6	36	24	20
		7V	34,9	40	39,1	32,2	28,9	19,9	19,3	43,8	39	27	23
		8V	35,9	40,7	39,9	33,4	30,5	20,8	18,1	44,6	40	28	24
9V		35,7	41,5	40,7	34,6	32	22,6	17	45,4	41	29	25	
10V	36,4	42,3	41,6	35,7	33,3	24,5	16,5	46,2	42	30	26		
LNH 8	Inlet + radiated	1V	28,7	18,7	13,5	12,5	16,7	16,1	17,1	30,0	<28	<20	/
		2V	30,5	23,5	18,5	14,5	17,9	17,7	18,7	32,1	<28	<20	/
		3V	33	30,8	26,3	18,5	20	19,8	20,8	36,0	29	<20	/
		4V	33,6	34,8	31	22,8	20,6	20	21	38,5	32	20	/
		5V	34,1	37,5	34,9	27	22,8	20,3	21,1	40,9	35	23	/
		6V	35,8	39,9	38,1	30,9	26,9	20,7	21,4	43,4	38	26	/
		7V	37,2	42,4	41,1	34,1	31	21,6	21,6	46,0	41	29	/
		8V	38,2	44	42,9	36,4	33,8	23	21,5	47,7	43	31	/
		9V	39,6	45,7	44,6	38,4	36,2	25,5	21,3	49,4	45	33	/
	10V	40,4	46,5	45,5	39,7	37,6	27,7	20,9	50,3	46	34	/	
	Outlet	1V	25,7	15,7	10,5	9,5	13,7	13,1	14,1	27,0	<28	<20	10
		2V	27,5	20,5	15,5	11,5	14,9	14,7	15,7	29,1	<28	<20	12
		3V	30	27,8	23,3	15,5	17	16,8	17,8	33,0	<28	<20	13
		4V	30,6	31,8	28	19,8	17,6	17	18	35,5	29	<20	14
		5V	31,1	34,5	31,9	24	19,8	17,3	18,1	37,9	32	20	15
		6V	32,8	36,9	35,1	27,9	23,9	17,7	18,4	40,4	35	23	19
		7V	34,2	39,4	38,1	31,1	28	18,6	18,6	43,0	38	26	22
		8V	35,2	41	39,9	33,4	30,8	20	18,5	44,7	40	28	24
9V		36,6	42,7	41,6	35,4	33,2	22,5	18,3	46,4	42	30	26	
10V	37,4	43,5	42,5	36,7	34,6	24,7	17,9	47,3	43	31	27		

	Speed	Sound power										Sound pressure	NR
		125Hz	250Hz	500Hz	1000Hz	2000Hz	4000Hz	8000Hz	500Hz	1000Hz	125Hz		
		dB	dB(A)	dB	dB	dB	dB	dB	dB	dB	dB	dB(A)	
LNH 12	Inlet + radiated	1V	27,8	17,5	14,1	12,7	16,9	16,2	17,1	29,3	<28	<20	/
		2V	29,4	27,7	23,4	15,5	17	16,5	17,9	32,7	<28	<20	/
		3V	31,3	34,3	32	24	20,2	17,3	18,1	37,9	32	<20	/
		4V	35,1	40,3	39	32	29,2	19,8	19,7	43,9	39	25	/
		5V	38,7	44,7	43,7	37,3	35,4	24,6	20,5	48,4	44	30	/
		6V	41,5	47,2	46,4	40,6	38,9	29,7	21	51,2	47	33	/
		7V	44	49,9	49	43,8	42,1	34,8	23,7	53,9	50	36	/
		8V	46,9	52,6	51,7	47,1	45,1	39,3	27,8	56,7	53	39	/
		9V	47,9	53,5	52,6	48,2	46,1	41,2	30,3	57,7	54	40	/
	10V	48,8	54,5	53,5	49,2	47,2	42,4	31,6	58,7	55	41	/	
	Outlet	1V	24,8	14,5	11,1	9,7	13,9	13,2	14,1	26,3	<28	<20	8
		2V	26,4	24,7	20,4	12,5	14	13,5	14,9	29,7	<28	<20	9
		3V	28,3	31,3	29	21	17,2	14,3	15,1	34,9	29	<20	10
		4V	32,1	37,3	36	29	26,2	16,8	16,7	40,9	36	22	18
		5V	35,7	41,7	40,7	34,3	32,4	21,6	17,5	45,4	41	27	23
		6V	38,5	44,2	43,4	37,6	35,9	26,7	18	48,2	44	30	25
		7V	41	46,9	46	40,8	39,1	31,8	20,7	50,9	47	33	28
		8V	43,9	49,6	48,7	44,1	42,1	36,3	24,8	53,7	50	36	31
9V		44,9	50,5	49,6	45,2	43,1	38,2	27,3	54,7	51	37	32	
10V	45,8	51,5	50,5	46,2	44,2	39,4	28,6	55,7	52	38	33		

8-DIMENSIONS AND WEIGHTS

1 - main coil input	2 - main coil output	A.R. : Air Return
3 - auxiliary coil input	4 - auxiliary coil output	A.D. : Air Delivery
5 - condensate drain		F.E. : filter extraction

Standard outfitting (right-hand connections)

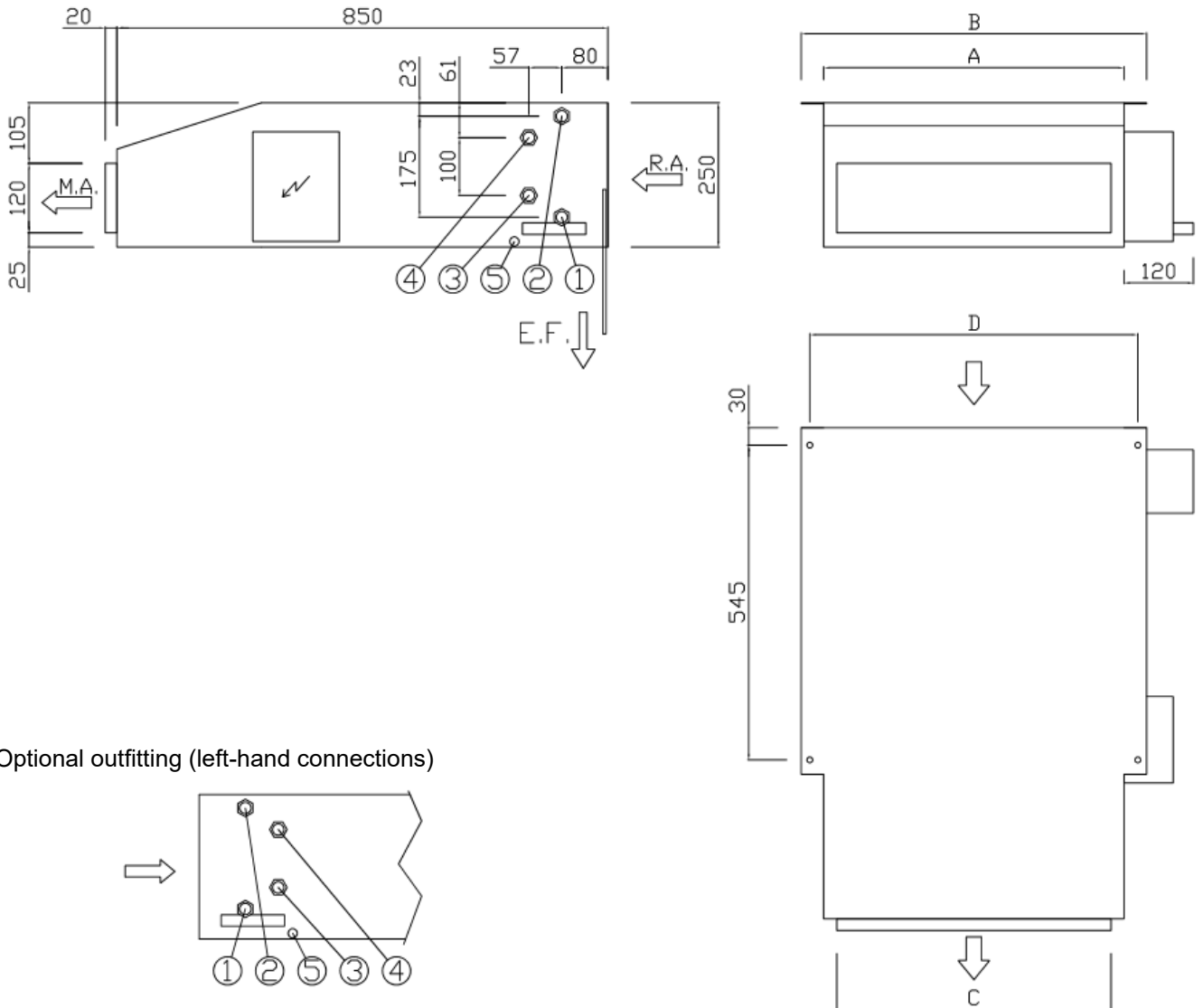

Optional outfitting (left-hand connections)

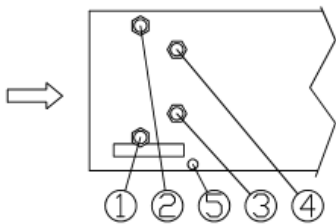

Unit with District Cooling coils have connectors in the positions shown in the drawings below, i.e. non-standard.

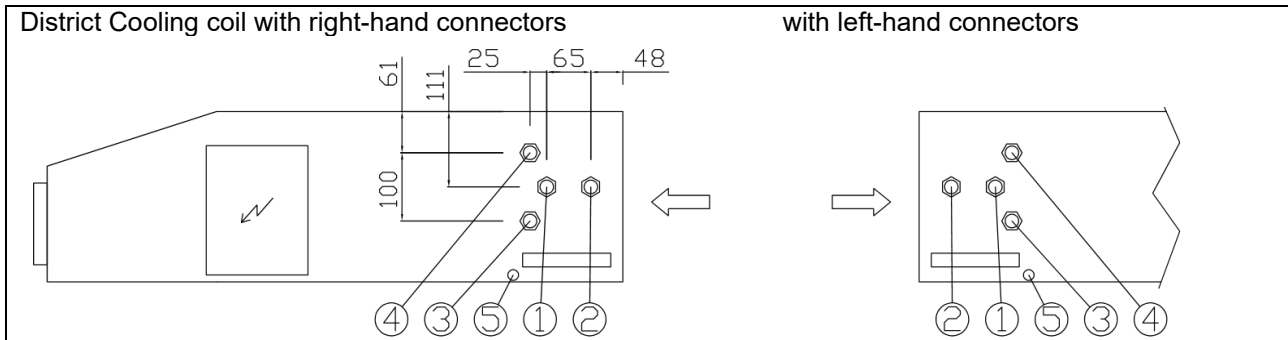

DIMENSIONS		3	6	8/12
A	mm	520	780	1040
B	mm	600	860	1120
C	mm	475	735	995
D	mm	570	830	1090
1 - Main coil INPUT	"	1/2"		
2 - Main coil OUTPUT	"	1/2"		
3 - Auxiliary coil INPUT	"	1/2"		
4 - Auxiliary coil OUTPUT	"	1/2"		
5 - horizontal condensate drain	mm	d.16		

WEIGHTS		3	6	8/12
Unit weight	kg	25	33	42
Main coil inside volume	litres	1.02	1.59	2.16
Auxiliary coil inside volume	litres	0.26	0.40	0.54

9-ACCESSORIES

HYDRAULIC ACCESSORIES		
1	B1	Auxiliary coil for 4-pipe systems
2	V	Valve (for the VBD dynamic balancing valve, see the specific manual)
3	PSC	Condensate drain pump
4	DET	Flexible hoses with ball valves
ELECTRICAL ACCESSORIES		
5	TR24	Transformer for modulating valve
6	ETBN-2.5A	Power relay board for master-slave
7	SC3	Three-speed EC motor control board
8	EH - EHR	Electrical heater - relay for electrical heaters
AEREAULIC ACCESSORIES		
9	RT	Telescopic plenum
10	PM90	90° delivery plenum
11	PMS	Delivery plenum with spigot
12	FRA	Air return flange
13	PA90	90° intake plenum
14	PAS	Intake plenum with spigot
15	PA90GF	90° plenum with return grille and filter
16	GM2	Dual adjustment delivery grille
17	GR	Return grille
18	COIB	Insulation for delivery plenum
19	FLAE	Flange for outdoor air intake
FILTRATION		
20	FAG3	Synthetic fibre filter class ISO COARSE (ISO 16890)
21	FA/SAN	Synthetic fibre filter class ISO COARSE (ISO 16890) with Sanitized treatment

NOTE: all plenums are supplied to non-insulated standards; to receive delivery plenums with condensation-preventing insulation, you must also order the COIB accessory.

The plenums can be supplied either fitted or not fitted to the fan coil, as may be chosen by the manufacturer based on packaging and transport needs.

Unless otherwise specified, the ordering codes for the accessories consist of the accessory code followed by the fan-coil size:

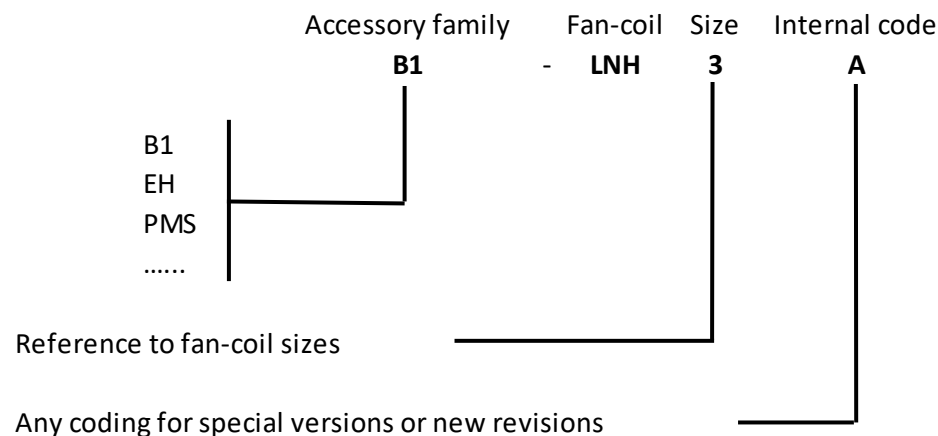

9.1-Auxiliary coil (B1)

The single-row auxiliary coil (B1) is used for heating purposes in 4-pipe systems. Feeding this coil with chilled water is not allowed, because it has no condensate collection tray. For correct management of heating and cooling, in 4-pipe systems it is necessary to provide motorized valves on both coils (main and auxiliary) ensuring that only one of the two coils is active.

9.2-Valves (V)

Servo-controlled valves should be used to prevent the formation of condensate on the surface of the unit when the fan has stopped.

The valves can be supplied assembled on the unit or as kits (disassembled components).

The auxiliary condensate collection tray is supplied with the unit as part of the standard equipment, without extra costs.

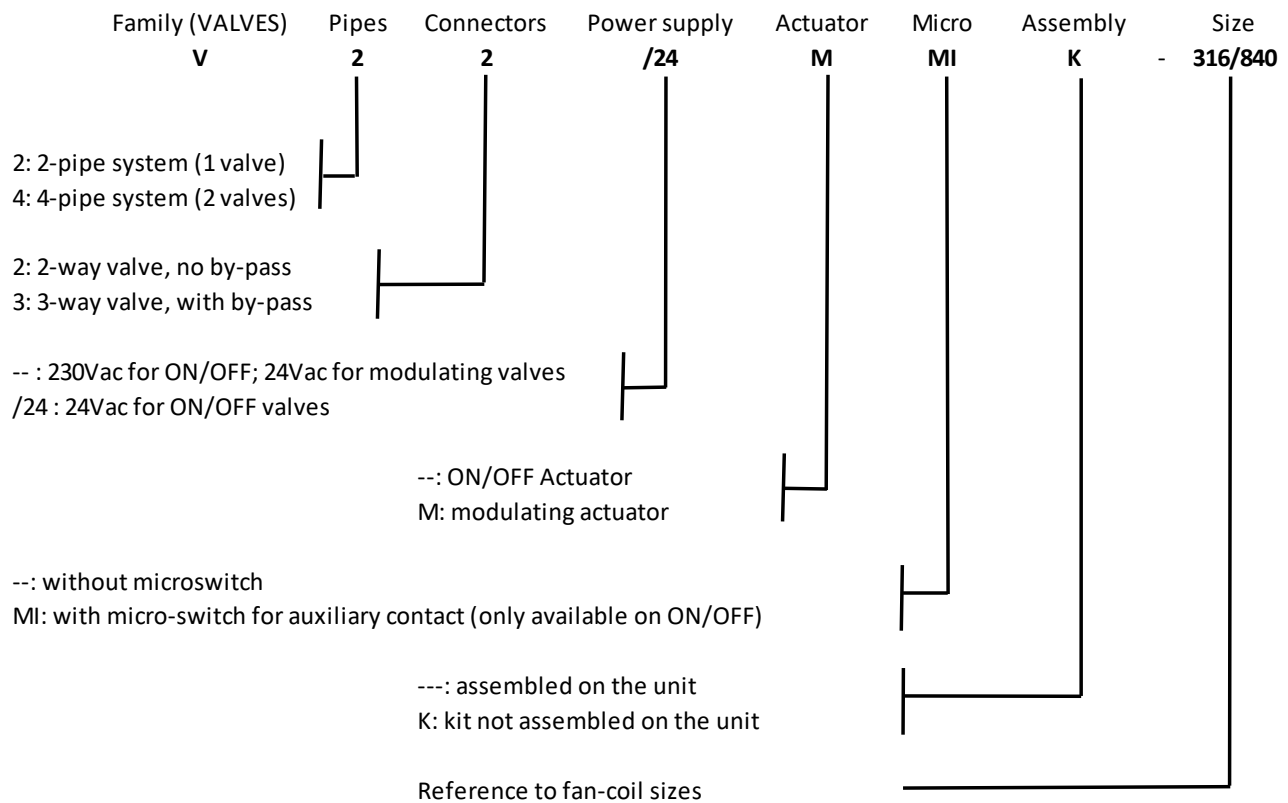

	VALVE FOR MAIN COIL (LNH 3 / 8)	VALVE FOR MAIN COIL (LNH 12)
	VALVE FOR MAIN COIL (LNH 3 / 12)	
GENERAL CHARACTERISTICS		
Connections size	1/2"	3/4"
Kv (2-way valve)	1.7	2.5
Kv (3-way valve, direct flow)	1.7	2.5
Kv (3-way valve, by-pass)	1.2	1.6
Max differential pressure	2.0bar	1.0bar
Nominal pressure	PN16	
Water temperature	5 – 110°C	
ACTUATOR ON/OFF		

Power supply	230V-50Hz (24V-50Hz on request)
Absorbed power	2.5W
Stroke time	180s
Characteristic (valve+actuator)	N.C. (Normally Closed)
Protection	IP44
MODULATING ACTUATOR	
Power supply	24Vac
Absorbed power	1.5W
Stroke time	8S
Control signal	0/10V
Control signal impedance	100k Ohm
Protection	IP43

1/2" valve pressure drop graph

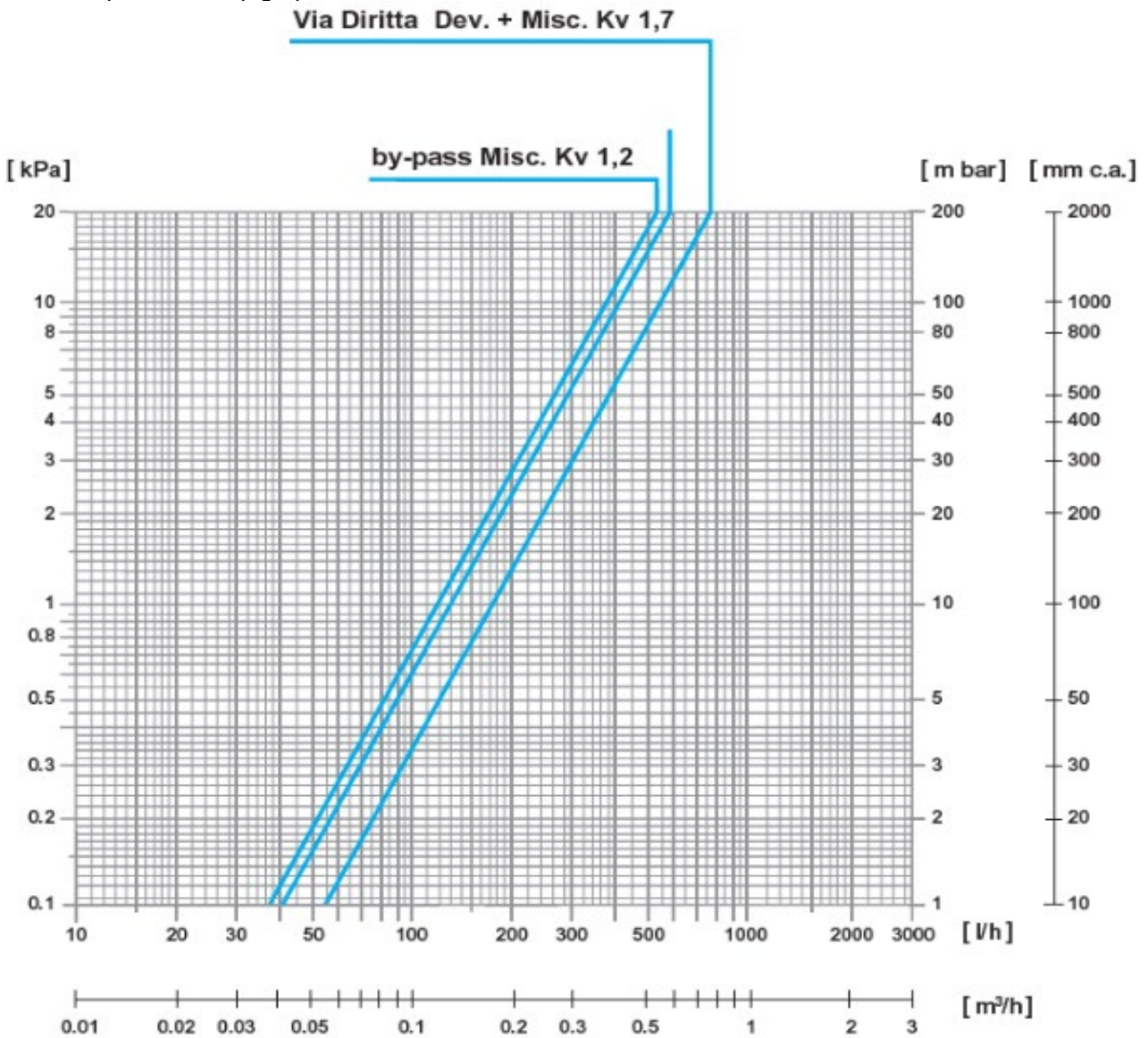

3/4" valve pressure drop graph

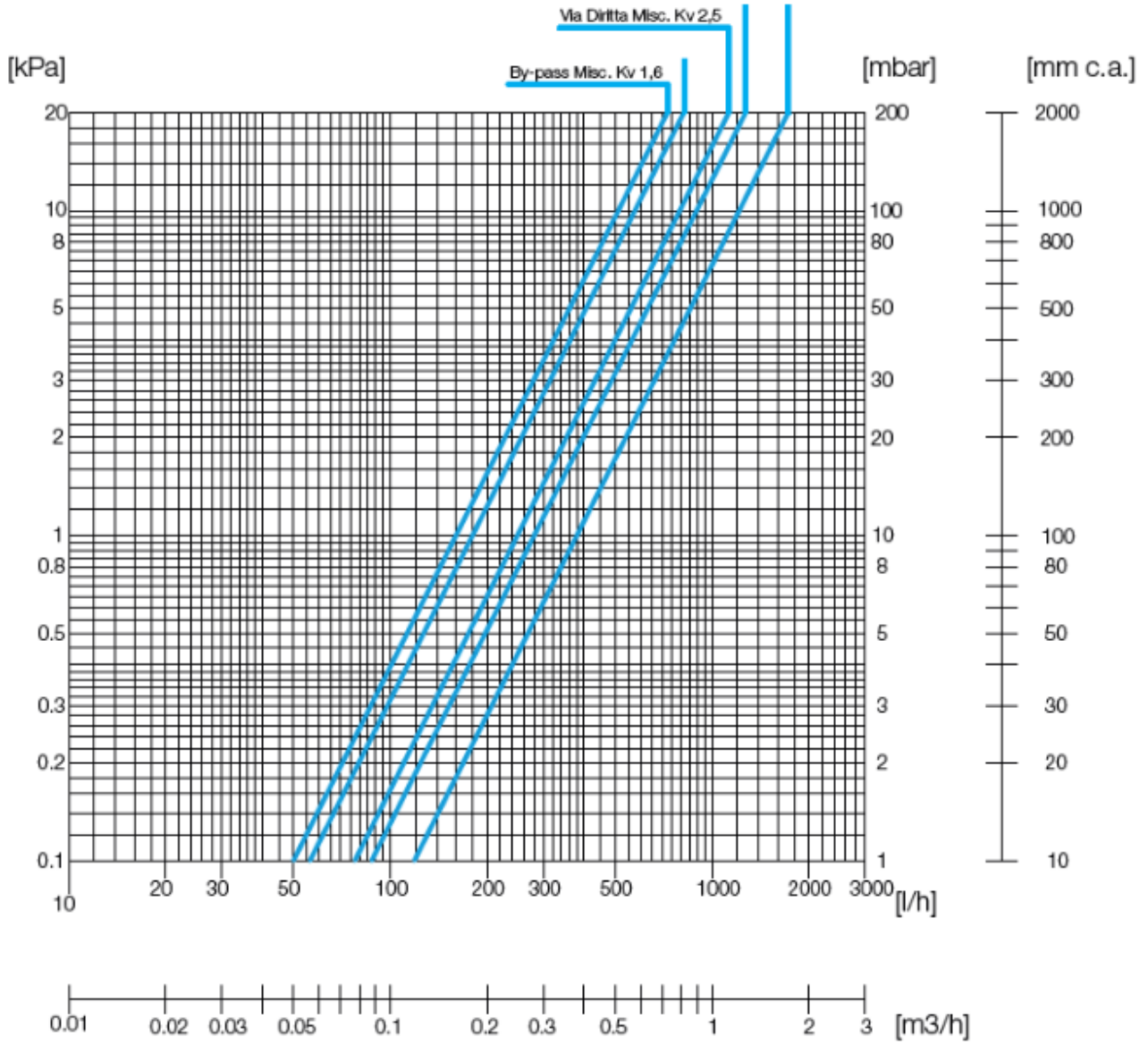

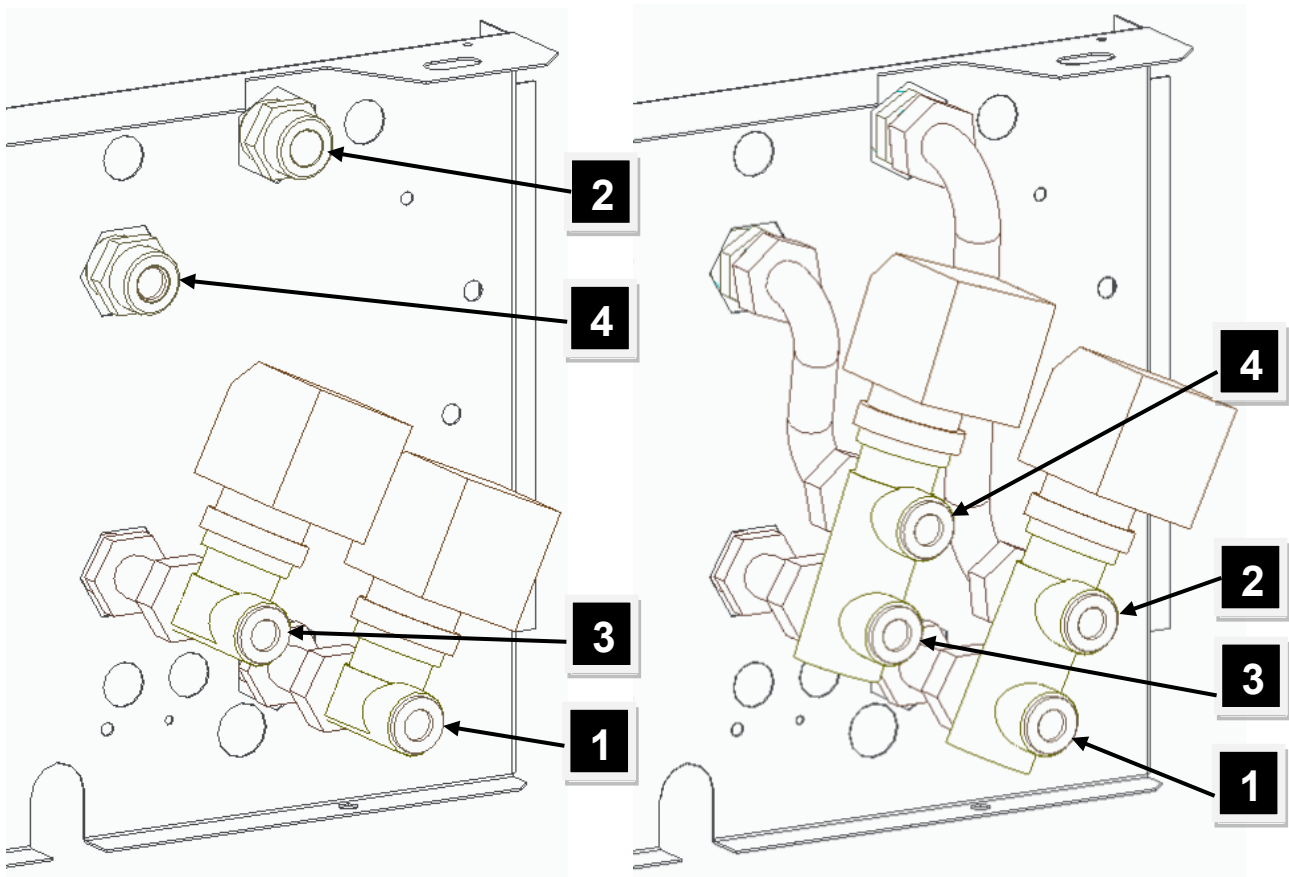

1 - main coil input	2 - main coil output
3 - auxiliary coil input	4 - auxiliary coil output

Dynamic balancing valves (VBD) are also available as accessories; for information please refer to the specific technical manual.

9.3-Condensate drain pump (PSC)

The condensate drain pumps can be supplied assembled on the unit or as kits (disassembled components).

Family (PUMPS) Assembly Fan-coil
PSC **/BI** - **LNH**

--: kit not assembled at the unit
 /BI : assembled on the unit

Maximum water flow rate	15 l/h
Maximum drainage height	6m (5 l/h)
Sound pressure at 1 m	20 dB(A)
Power supply	230V – 50/60Hz
Alarm microswitch	Resistive NC 5A 250V
Circuit breaker	automatic reset
Protection	IP64
Power draw	19W

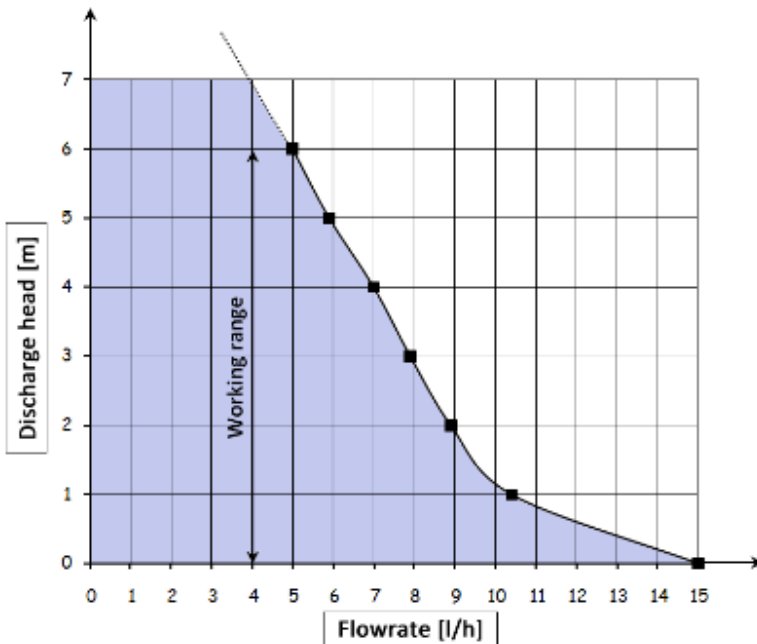

9.4-Flexible hoses with ball valves (DET)

The flexible hoses with ball valves are supplied as kits (disassembled components). Their use simplifies the hydraulic connection of fan-coils and, thanks to the ball valves, allows for valve and coil maintenance without having to completely drain the system.



External metal braid material	AISI304 stainless steel
Internal material	EPDM
Fittings and elbows material	Brass, chrome-plated brass, copper
Ball valve material	Chrome plated brass
Maximum working pressure	10 bar
Water temperature	5 - 85°C
Hose length	190mm
Hose length + valve	240mm (+/- 5)

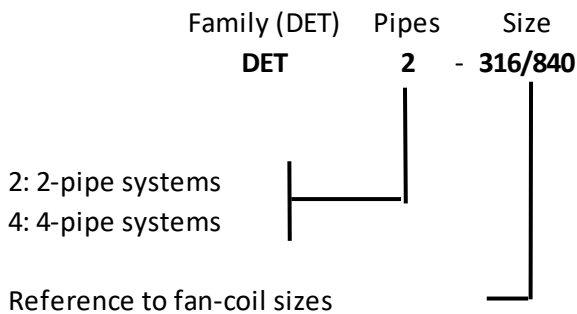

9.5-Transformer for modulating valves (TR24)

The TR24 accessory is a 230Vac - 24Vac 20VA transformer needed to power the modulating valves. In the event that there are two modulating valves for the same unit (4-pipe system), only one transformer is sufficient to supply both valves.

TR24 is available in one size, suitable for all unit sizes.

9.6-Power relay board for master-slave (ETBN-2.5A)

The power relay board (ETBN-2.5A) is needed to control more than one unit with AC motor (three speeds) with a single control. In this case, one ETBN-2.5A is required for each unit. This board is also necessary to control a single unit, when the control is not able to carry the highest current draw by the motor. For more information on this accessory, please refer to its specific technical manual.

The ETBN-2.5A board is available in one size, suitable for all unit sizes.

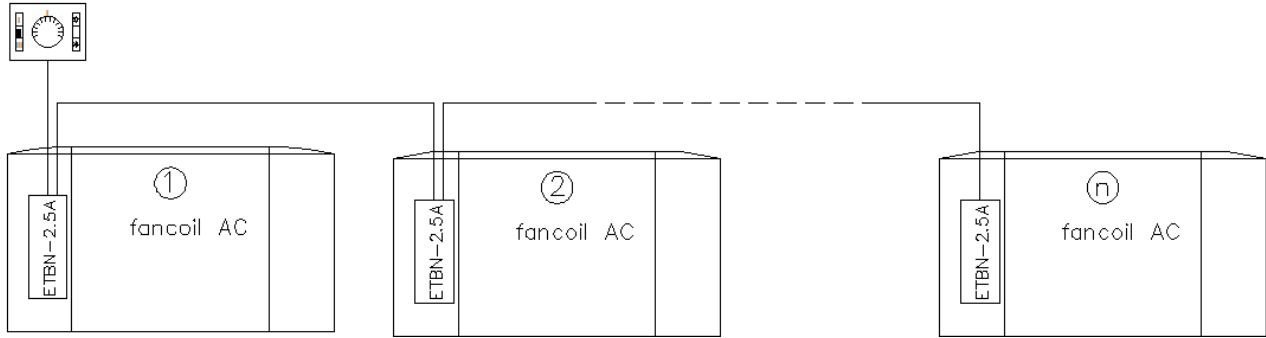

(*)

9.7-Three-speed EC motor control board (SC3)

The SC3 board allows an EC motor (with 0/10V signal) to be controlled through a common three speed control for AC motors. It is possible to control several (up to 20) units equipped with SC3 through a single control. For more information on this accessory, please refer to its specific technical manual.

The SC3 board is available in one size, suitable for all unit sizes.

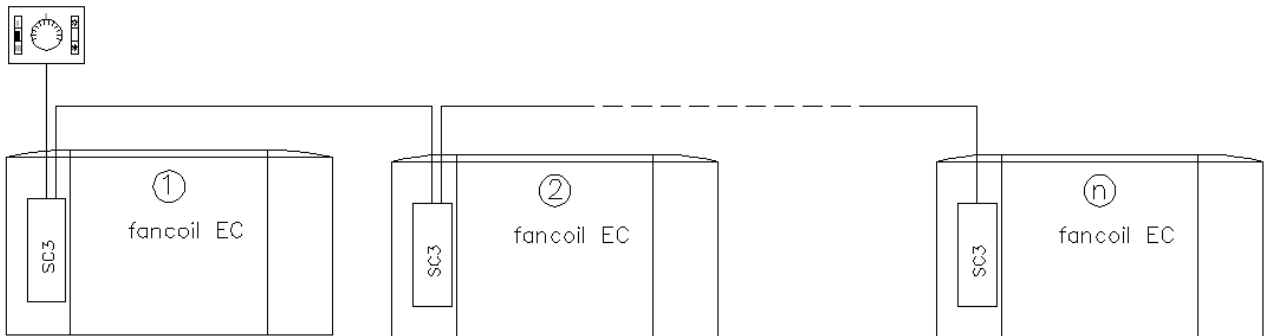

(*)

(*)The pictures are for illustrative purposes only.

9.8-Plenum with electrical heater (PEH) and relay (EHR)

The plenum with electric heaters, made of galvanised metal pate, must be installed on the delivery end. The electric heaters are made of aluminium and are equipped with a safety thermostat against overheating. To control the heaters, it is recommended to use the EHR (power relay) accessory.

For correct dissipation of the heat generated by the electric heaters, it is recommended to never use the minimum fan speed and to use instead the maximum and medium speed settings (to be chosen also in relation to the pressure drops in the ducting). After the heaters are turned off, it is recommended to leave the fan on for a few minutes (at least two minutes) to allow the electric heaters to cool.

It is therefore strongly recommended to use an AERTESI control, chosen from those with a specific setting for the electric heater mode."

	3	6	8/12
Power	1.0 kW	1.25 kW	2.0 kW
Power supply	230V-50Hz single-phase		
No. of stages	1	1	1
Power relays to be used	EHR-8A	EHR-8A	EHR-20A

Two relay sizes are available, according to the table below:

	EHR-8A	EHR-20A
Maximum contact current (resistive load)	8 A	20 A
Coil power supply	230V-50Hz single-phase	
No. of contacts	2	4

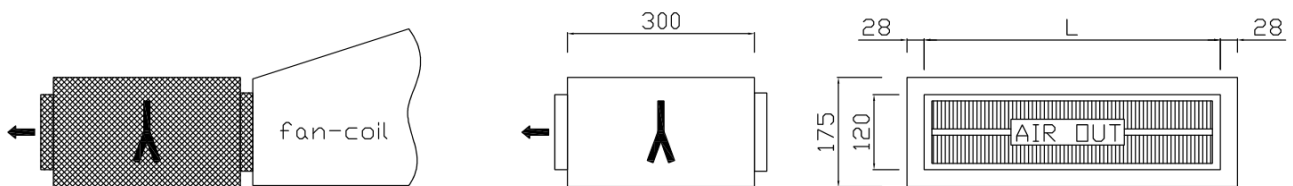

Fan-coil size	3	6	8/12
L (mm)	475	735	995

9.9-Telescopic coupling (RT)

The telescopic coupling can be used when it is necessary to adjust the distance between the unit delivery and another element (for example the delivery grille or a duct). It is composed of two elements sliding one inside the other and can cover a distance ranging between 150 and 240mm. The size of the plenum delivery outlet is compatible with the size of the GM2 delivery grille.

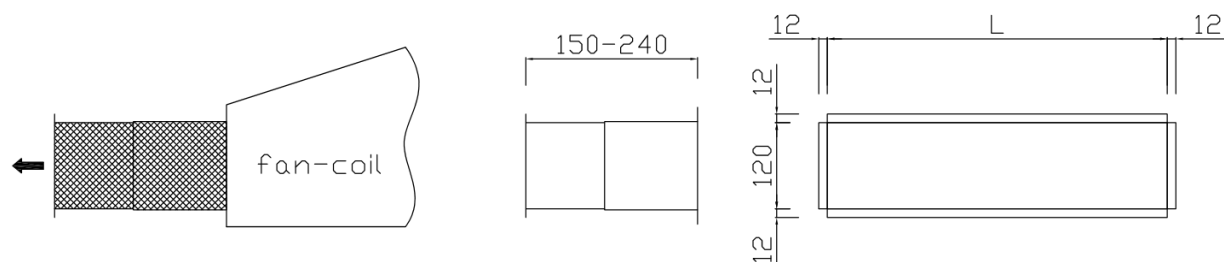

Fan-coil size	3	6	8/12
L (mm)	475	735	995

9.10-90° Delivery plenum (PM90)

The 90° delivery plenum can be used when the air delivery outlet must be pointing downwards. The size of the plenum delivery outlet is compatible with the size of the GM2 delivery grille.

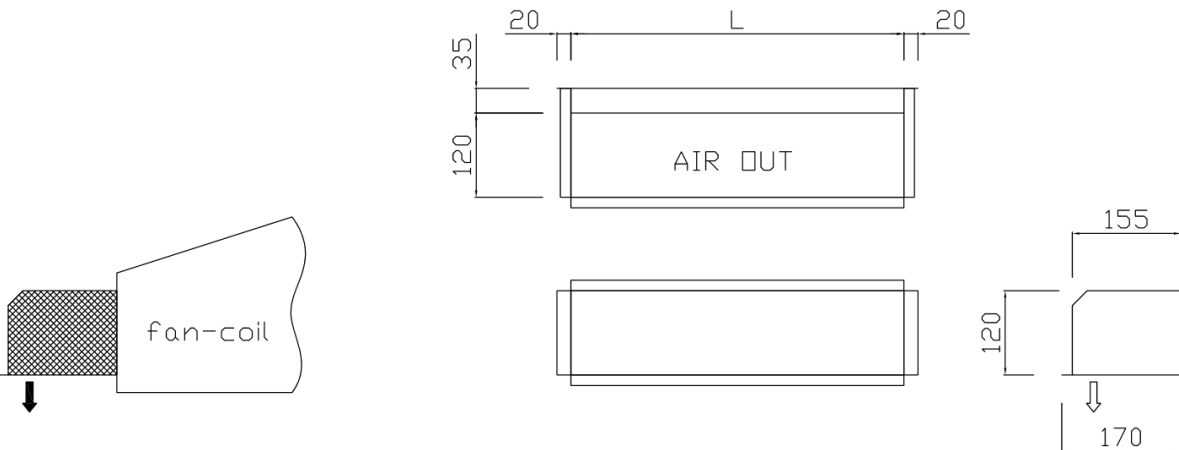

Fan-coil size	3	6	8/12
L (mm)	475	735	995

9.11-Delivery plenum with spigot (PMS)

The delivery plenum with flared sleeves can be used when it is necessary to connect circular ducts to the delivery end.

The flared sleeves are of the type suitable for connecting flexible hoses for conditioning systems, therefore the actual outside diameter of the sleeve is approximately 5mm smaller than the nominal inside diameter of the pipe to be connected.

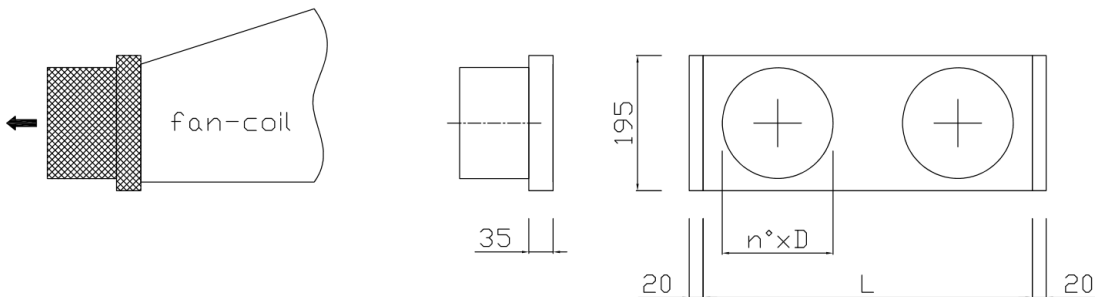

Fan-coil size	3	6	8/12
L (mm)	475	735	995
n. x D (mm)	1 x ø160	2 x ø160	3 x ø160
D = nominal inside diameter of the hose to be connected			

9.12-Air return flange (FRA)

The air return flange can be used when it is necessary to channel the air intake. The size of the intake outlet is compatible with the size of the GR return grille.

The return flange is also necessary to connect some plenums to the unit intake; on this subject, please refer to the specific paragraph of each plenum.

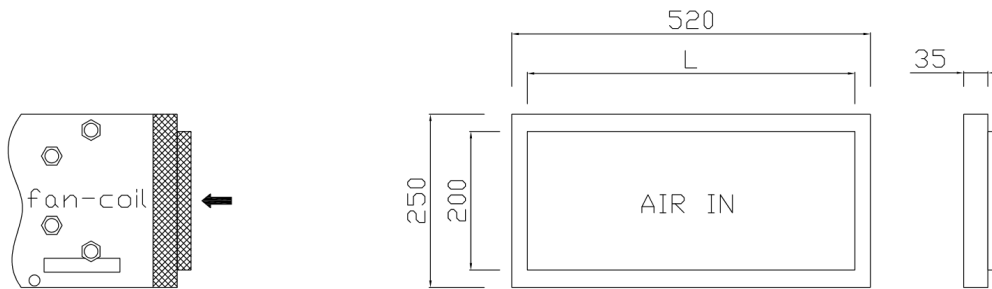

Fan-coil size	3	6	8/12
L (mm)	475	735	995

9.13-90° Intake plenum (PA90)

The 90° intake plenum can be used when the air intake outlet must be pointing downwards. The size of the plenum delivery outlet is compatible with the size of the GR return grille.

In order to connect the accessory to the unit, the FRA accessory must be interposed.

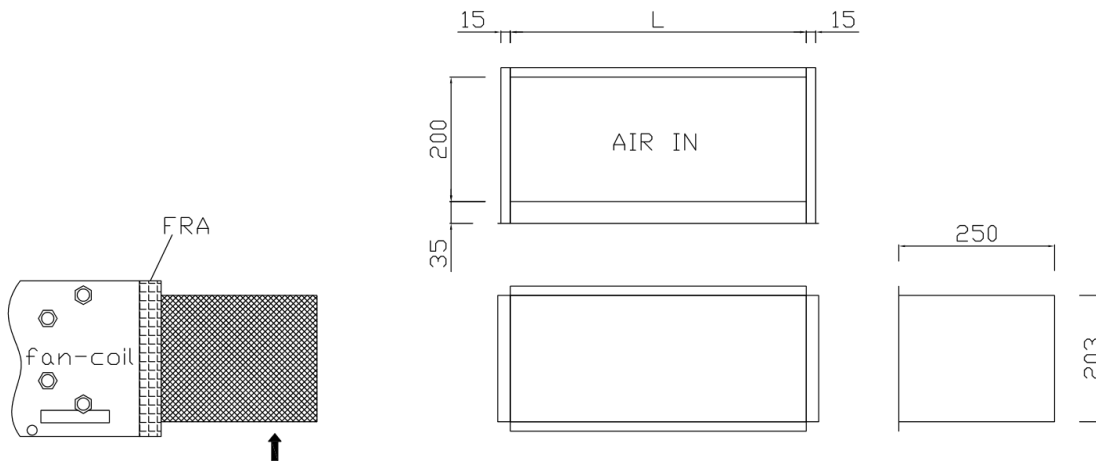

Fan-coil size	3	6	8/12
L (mm)	475	735	995

9.14-Intake plenum with spigot (PAS)

The intake plenum with flared sleeves can be used when it is necessary to connect circular ducts to the intake end.

The flared sleeves are of the type suitable for connecting flexible hoses for conditioning systems, therefore the actual outside diameter of the sleeve is approximately 5mm smaller than the nominal inside diameter of the pipe to be connected.

In order to connect the accessory to the unit, the FRA accessory must be interposed.

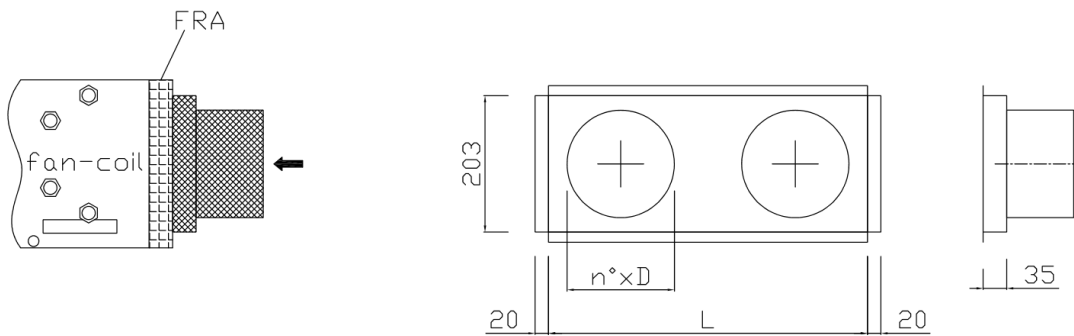

Fan-coil size	3	6	8/12
L (mm)	475	735	995
n. x D (mm)	1 x \varnothing 160	2 x \varnothing 160	3 x \varnothing 160
D = nominal inside diameter of the hose to be connected			

9.15-90° plenum with return grille and filter (PA90GF)

The 90° return plenum can be used when the air intake outlet must be pointing downwards, with the return grille applied directly to the plenum. This accessory is a kit consisting of the following components:

- 90° return plenum
- Telescopic return fitting, to adapt to the height of the false ceiling
- Return grille with inspectable filter

1	90° return plenum
2	Telescopic coupling
3	Filter
4	Return grille
5	False ceiling

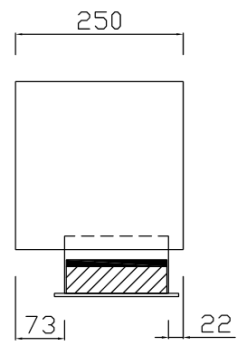
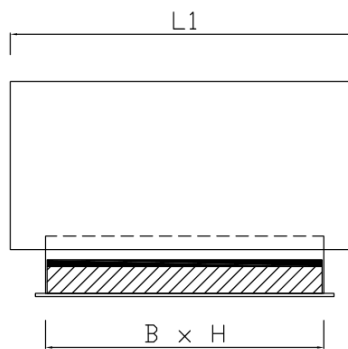
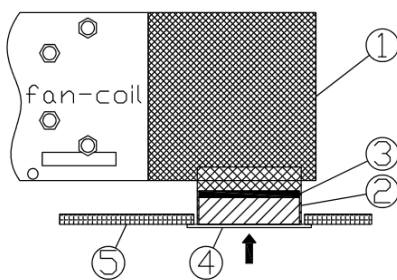
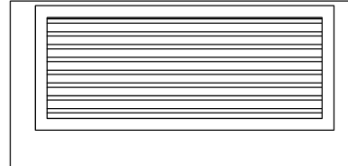

Fan-coil size	3	6	8/12
L1 (mm)	520	780	1040
B x H (mm)	415x155	675x155	935x155
B x H: nominal dimensions of the hole			

9.16-Dual adjustment delivery grille (GM2)

The delivery grille is made of RAL 9016 (white) painted aluminium. It is equipped with two rows of fins, which allow for double adjustment of the air flow: vertically and horizontally.

The frame is provided with holes for fixing the grille by means of screws (not supplied) which must be chosen according to the support material.

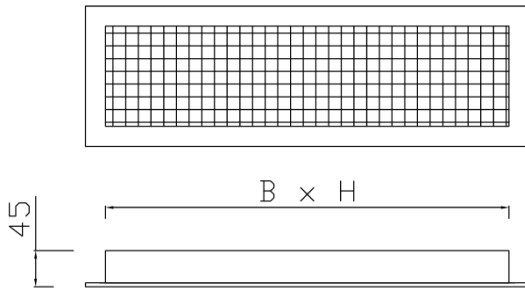

Fan-coil size	3	6	8/12
B x H (mm)	475x120	735x120	995x120
B x H: nominal dimensions of the hole			

9.17-Return grille (GR)

The return grille is made of RAL 9016 (white) painted aluminium. It has fixed horizontal fins, making the inside of the duct barely visible.

The frame is provided with holes for fixing the grille by means of screws (not supplied) which must be chosen according to the support material.

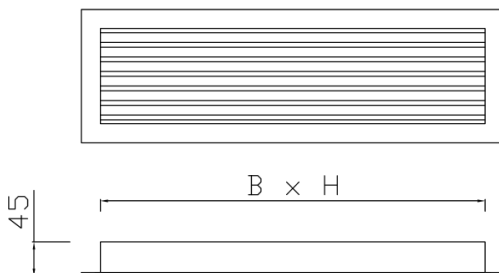

Fan-coil size	3	6	8/12
B x H (mm)	475x200	735x200	995x200
B x H: nominal dimensions of the hole			

9.18- Insulation for plenum (COIB)

When the plenums are installed on the delivery end, the COIB accessory must also be added, since the plenums supplied as part of the standard equipment are NOT insulated. The insulation, made of 3mm thick closed cell polyethylene, prevents condensation from collecting on the outside of the plenum when cold air flows through it.

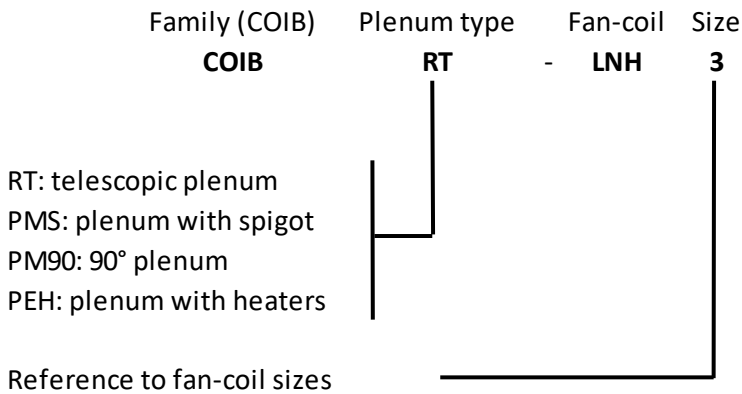

9.19-Flange for external air intake (FLAE)

The external air intake flange can be used when fresh air must be introduced from the outside. It is located at the unit return end and therefore the size of the flange for the recirculated air is reduced.

The flared sleeve is of the type suitable for connecting flexible hoses for conditioning systems, therefore the actual outside diameter of the sleeve is approximately 5mm smaller than the nominal inside diameter of the pipe to be connected.

The fresh air must be previously treated through a heat recovery unit or similar units. Direct intake of outdoor air is not allowed.

In order to connect the accessory to the unit, the FRA accessory must be interposed.

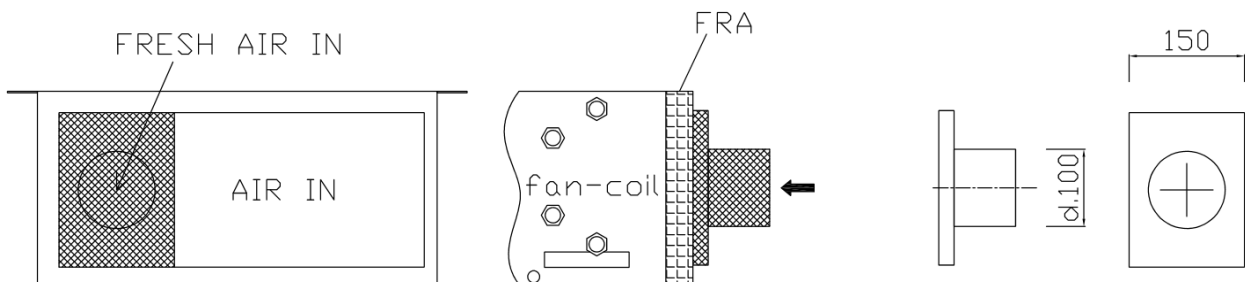

9.20-Synthetic fibre filter (FAG3)

The FAG3 synthetic fibre filter, classified ISO COARSE (ISO 16890) guarantees greater filtration efficiency than a standard filter, although it falls in the same class of filtration. This filter is NOT washable and must be replaced when it is dirty.

9.21-Filter in synthetic fibre with Sanitized treatment (FA/SAN)

The FA/SAN synthetic fibre filter, classified ISO COARSE (ISO 16890) guarantees greater filtration efficiency than a standard filter, although it falls in the same class of filtration. Additionally, thanks to the special Sanitized treatment, it has an antibacterial effect and prevents fungal growth. This filter is NOT washable and must be replaced when it is dirty. More information and certificates relating to the tests carried out are available from our sales office.

10-ELECTRICAL CONNECTIONS

The electrical panel, based on the chosen configuration of the accessories, can consist of a sheet metal box or a plastic box.

Given the wide range of available accessories and their combinations, this manual only shows the wiring diagram of the "basic" unit, i.e. a three-speed AC or EC motor with 0/10V signal and 230V valves. Each machine is supplied with its specific wiring diagram, based on the chosen equipment.

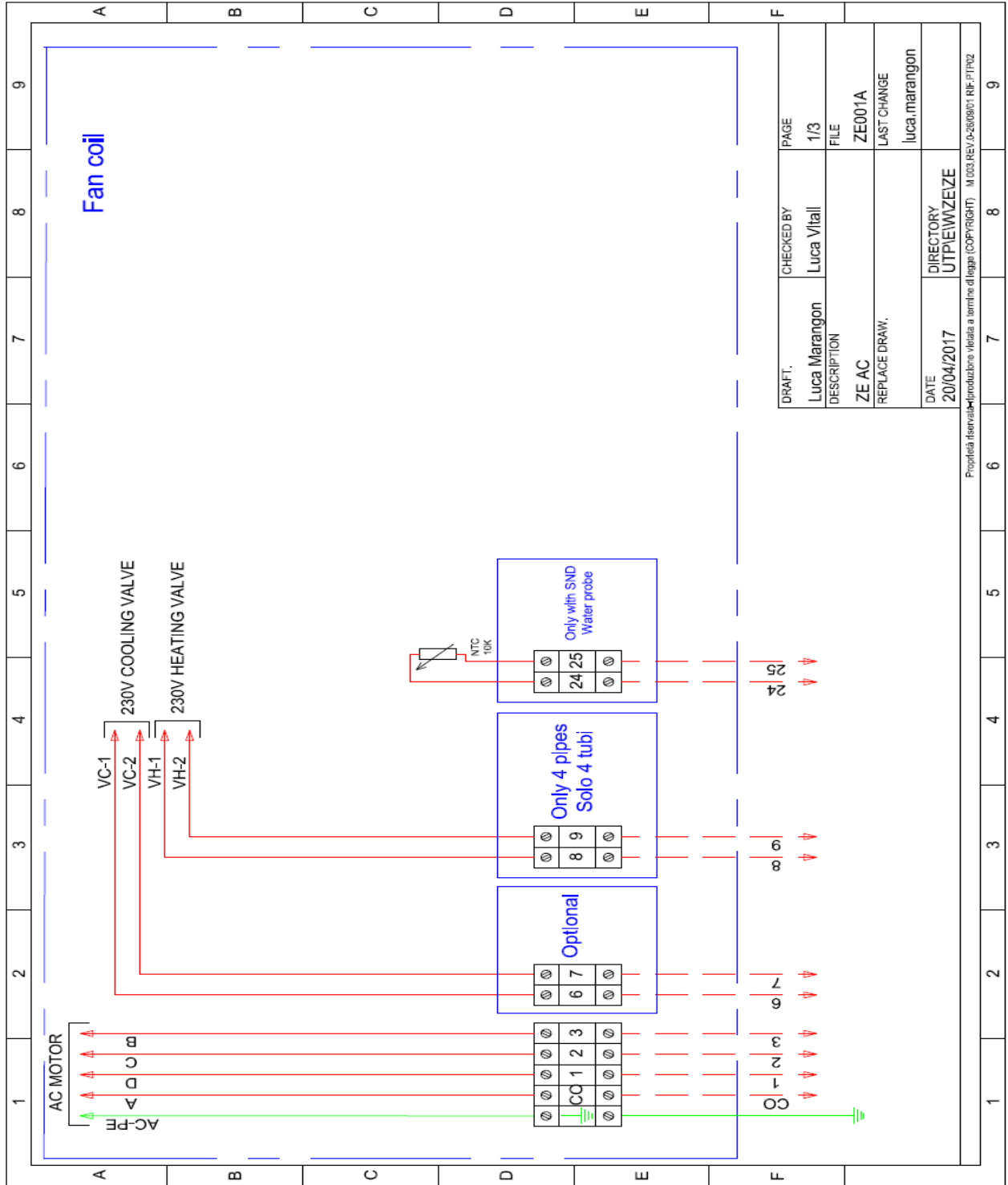

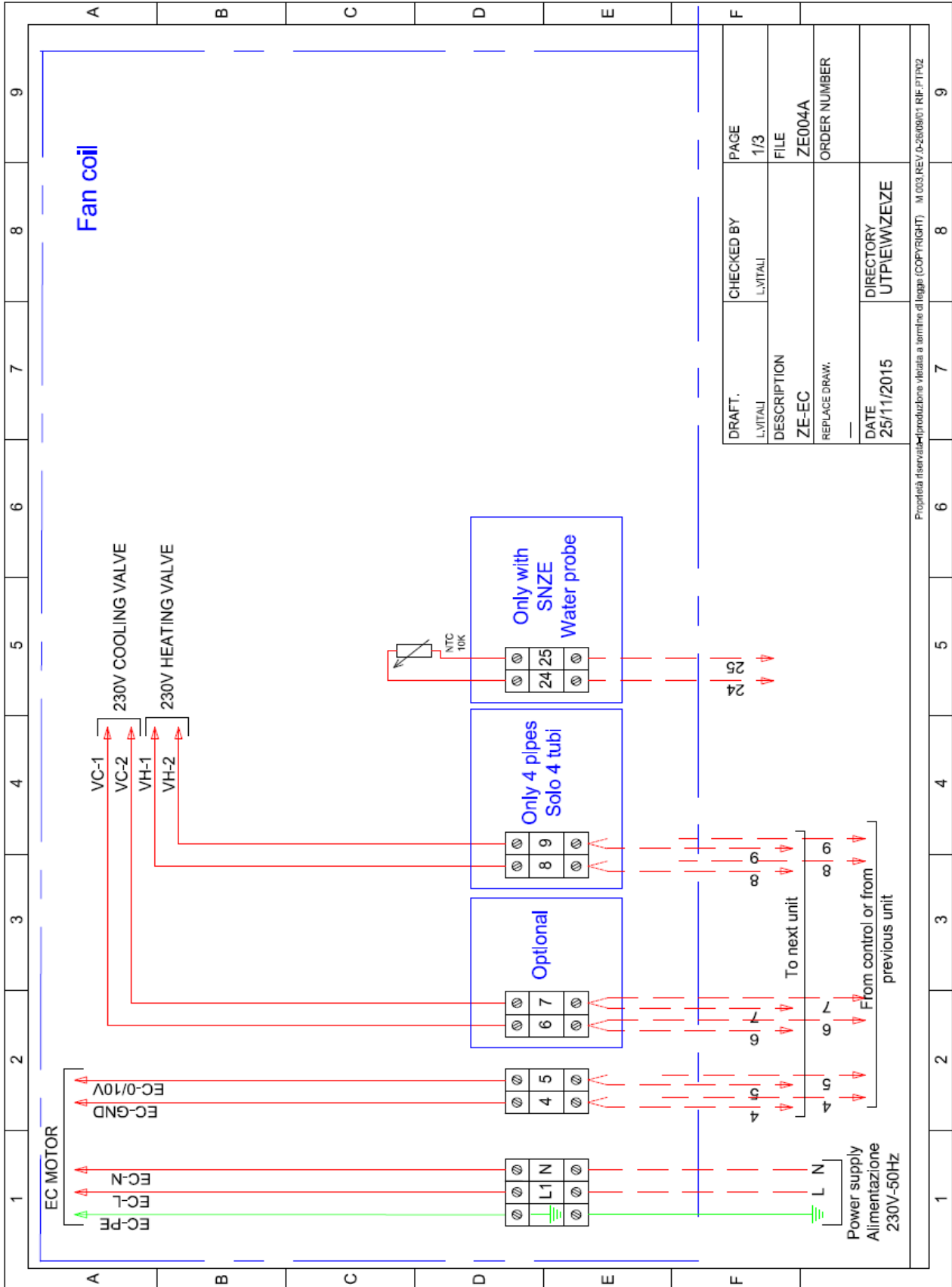



EXTERNAL THERMOSTAT CONTROLS	
CO	Common fan
1	Minimum fan speed (line)
2	Medium fan speed (line)
3	Maximum fan speed (line)
4	Reference with 0-10V signal
5	0-10V signal for motor control
6	Common 2-pipe valve / 4-pipe cold valve (neutral)
7	Common 2-pipe valve / 4-pipe cold valve (line)
8	Common 4-pipe hot valve (neutral) - only if available
9	4-pipe hot valve signal (line) - only if available
24-25	NTC water probe - only if available
26-27	NTC remote air probe - only if available

NOTES:

Aertesi srl reserves the right to introduce any changes considered necessary to improve the product by editing the related technical data at any time



something different

AER.MT.LNH.GB.008.09.22

Aertesi srl
viale della tecnica, 6/a
35026 Conselve (PD) ITALY
t. +39.049.9501109
f. +39.049.9500823
www.aertesi.com
info@aertesi.com